

# KENWOOD

## **Document Copyrights**

Copyright 2006 by Kenwood Corporation. All rights reserved.

No part of this manual may be reproduced, translated, distributed, or transmitted in any form or by any means, electronic, mechanical, photocopying, recording, or otherwise, for any purpose without the prior written permission of Kenwood.

## **Disclaimer**

While every precaution has been taken in the preparation of this manual, Kenwood assumes no responsibility for errors or omissions. Neither is any liability assumed for damages resulting from the use of the information contained herein. Kenwood reserves the right to make changes to any products herein at any time for improvement purposes.

This TK-8100H service manual contains a number of sections which differ from the service manual (B51-8646-00) for the TK-8100H.  
For items other than those in this TK-8100H service manual please refer to the service manual (B51-8646-00) for the TK-8100H.



## CONTENTS

<b>GENERAL .....</b>	<b>2</b>	<b>PC BOARD</b>	
<b>SYSTEM SET-UP .....</b>	<b>3</b>	<b>DISPLAY UNIT (X54-3430-20) .....</b>	<b>19</b>
<b>PARTS LIST .....</b>	<b>4</b>	<b>TX-RX UNIT (X57-6710-XX) .....</b>	<b>21</b>
<b>EXPLODED VIEW .....</b>	<b>11</b>	<b>SCHEMATIC DIAGRAM .....</b>	<b>27</b>
<b>PACKING .....</b>	<b>12</b>	<b>BLOCK DIAGRAM .....</b>	<b>31</b>
<b>ADJUSTMENT .....</b>	<b>13</b>	<b>LEVEL DIAGRAM .....</b>	<b>33</b>
<b>TERMINAL FUNCTION .....</b>	<b>18</b>	<b>SPECIFICATION .....</b>	<b>35</b>

## GENERAL

### INTRODUCTION

#### SCOPE OF THIS MANUAL

This manual is intended for use by experienced technicians familiar with similar types of commercial grade communications equipment. It contains all required service information for the equipment and is current as of this publication date. Changes which may occur after publication are covered by either Service Bulletins or Manual Revisions, which are issued as required.

### ORDERING REPLACEMENT PARTS

When ordering replacement parts or equipment information, the full part identification number should be included. This applies to all parts : components, kits, and chassis. If the part number is not known, include the chassis or kit number of which it is a part and a sufficient description of the required component for proper identification.

### PERSONNEL SAFETY

The following precautions are recommended for personnel safety :

- DO NOT transmit if someone is within two feet (0.6 meter) of the antenna.
- DO NOT transmit until all RF connectors are secure and any open connectors are properly terminated.
- SHUT OFF this equipment when near electrical blasting caps or while in an explosive atmosphere.
- All equipment should be properly grounded before power-up for safe operation.
- This equipment should be serviced by only qualified technicians.

### PRE-INSTALLATION CONSIDERATIONS

#### 1. UNPACKING

Unpack the radio from its shipping container and check for accessory items. If any item is missing, please contact KENWOOD immediately.

#### 2. LICENSING REQUIREMENTS

Federal regulations require a station license for each radio installation (mobile or base) be obtained by the equipment owner. The licensee is responsible for ensuring transmitter power, frequency, and deviation are within the limits permitted by the station license.

Transmitter adjustments may be performed only by a licensed technician holding an FCC first, second or general class commercial radiotelephone operator's license. There is no license required to install or operate the radio.

### 3. PRE-INSTALLATION CHECKOUT

#### 3-1. Introduction

Each radio is adjusted and tested before shipment. However, it is recommended that receiver and transmitter operation be checked for proper operation before installation.

#### 3-2. Testing

The radio should be tested complete with all cabling and accessories as they will be connected in the final installation. Transmitter frequency, deviation, and power output should be checked, as should receiver sensitivity, squelch operation, and audio output. Signalling equipment operation should be verified.

### 4. PLANNING THE INSTALLATION

#### 4-1. General

Inspect the vehicle and determine how and where the radio antenna and accessories will be mounted.

Plan cable runs for protection against pinching or crushing wiring, and radio installation to prevent overheating.

#### 4-2. Antenna

The favored location for an antenna is in the center of a large, flat conductive area, usually at the roof center. The trunk lid is preferred, bond the trunk lid and vehicle chassis using ground straps to ensure the lid is at chassis ground.

#### 4-3. Radio

The universal mount bracket allows the radio to be mounted in a variety of ways. Be sure the mounting surface is adequate to support the radio's weight. Allow sufficient space around the radio for air cooling. Position the radio close enough to the vehicle operator to permit easy access to the controls when driving.

#### 4-4. DC Power and wiring

1. This radio may be installed in negative ground electrical systems only. Reverse polarity will cause the cable fuse to blow. Check the vehicle ground polarity before installation to prevent wasted time and effort.
2. Connect the positive power lead directly to the vehicle battery positive terminal. Connecting the Positive lead to any other positive voltage source in the vehicle is not recommended.
3. Connect the ground lead directly to the battery negative terminal.
4. The cable provided with the radio is sufficient to handle the maximum radio current demand. If the cable must be extended, be sure the additional wire is sufficient for the current to be carried and length of the added lead.

## GENERAL / SYSTEM SET-UP

### 5. INSTALLATION PLANNING – CONTROL STATIONS

#### 5-1. Antenna system

Control station. The antenna system selection depends on many factors and is beyond the scope of this manual. Your KENWOOD dealer can help you select an antenna system that will best serve your particular needs.

#### 5-2. Radio location

Select a convenient location for your control station radio which is as close as practical to the antenna cable entry point. Secondly, use your system's power supply (which supplies the voltage and current required for your system). Make sure sufficient air can flow around the radio and power supply to allow adequate cooling.

### NOTE

If you do not intend to use the 3.5-mm jack for the external speaker, fit the supplied speaker-jack cap to stop dust and sand from getting in.

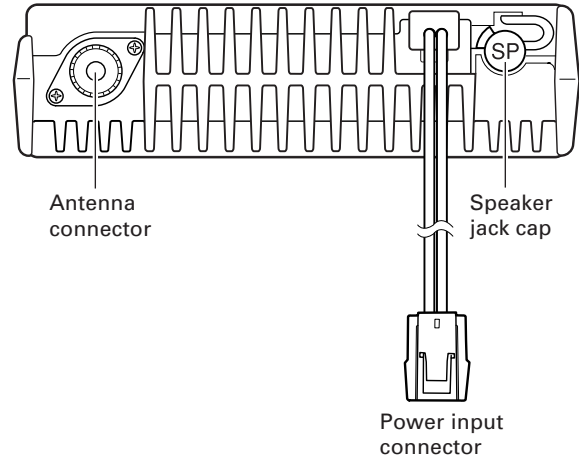

### SERVICE

This radio is designed for easy servicing. Refer to the schematic diagrams, printed circuit board views, and alignment procedures contained in this manual.

### SYSTEM SET-UP

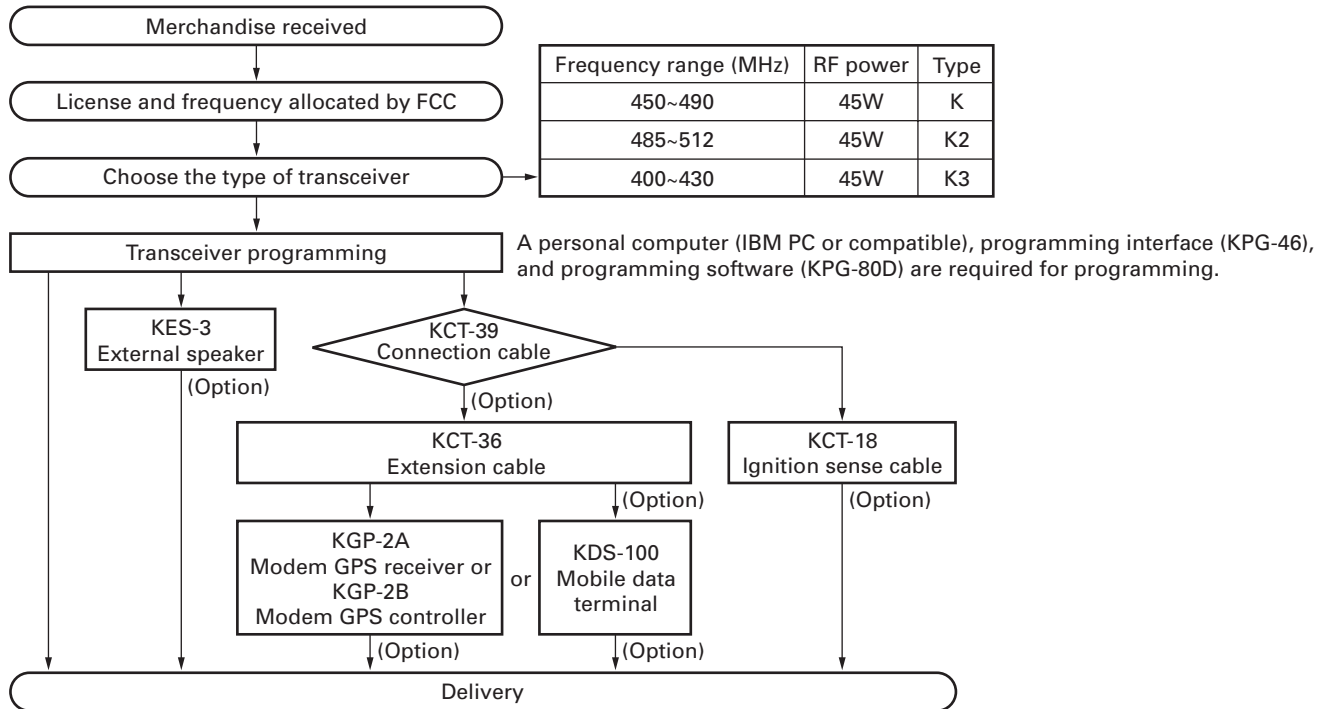

# TK-8100H

## PARTS LIST

\* New Parts.  indicates safety critical components.

Parts without **Parts No.** are not supplied.

Les articles non mentionnés dans le **Parts No.** ne sont pas fournis.

Teile ohne **Parts No.** werden nicht geliefert.

**L** : Scandinavia

**Y** : PX (Far East, Hawaii)

**Y** : AAFES (Europe)

**K** : USA

**T** : England

**X** : Australia

**P** : Canada

**E** : Europe

**M** : Other Areas

### TK-8100H, DISPLAY UNIT (X54-3430-20)

### TX-RX UNIT (X57-6710-XX)

Ref. No.	Address	New parts	Parts No.	Description	Destination
<b>TK-8100H</b>					
1	1B		A01-2181-01	CABINET	
2	3B		A10-4048-21	CHASSIS	
3	3A		A62-1074-03	PANEL ASSY	
5	3A		B11-1299-02	ILLUMINATION GUIDE	
6	3A		B38-0878-05	LCD	
8	1D		B62-1673-00	INSTRUCTION MANUAL (ENGLISH)	
9	1D		B62-1674-00	INSTRUCTION MANUAL (SPANISH)	
10	3B		B72-2115-04	MODEL NAME PLATE	K
10	3B	*	B72-2116-04	MODEL NAME PLATE	K2
10	3B	*	B72-2117-04	MODEL NAME PLATE	K3
12	3B		E04-0167-05	RF COAXIAL RECEPTACLE (M)	
13	3A		E29-1197-15	INTER CONNECTOR	
14	3C		E30-3339-05	DC CORD ACCESSORY	
15	2B		E30-3448-05	DC CORD (RADIO)	
16	2A		E37-1041-05	FLAT CABLE	
-			E37-1080-05	FOR SCRAMBLER BOARD (B)	
-			E37-1081-05	FOR SCRAMBLER BOARD (A)	
19	3A		E37-1082-05	SPEAKER CABLE	
21	2B		F10-2449-01	SHIELDING COVER	
22	3C		F51-0017-05	FUSE (6*30) ACCESSORY	
24	2B		G02-0894-04	EARTH SPRING (FINAL FET)	
25	3B		G11-4127-14	RUBBER SHEET (CHASSIS)	
26	2B		G11-4240-04	RUBBER SHEET (DRIVE FET)	
27	3B		G13-1468-04	CUSHION (DC CORD)	
-			G13-1963-04	CUSHION (SCRAMBLER BOARD)	
-			G13-1964-04	CUSHION (SCRAMBLER BOARD)	
-			G13-1972-04	CUSHION (TRUNKING BOARD)	
30	3A		G53-1525-03	PACKING (PANEL)	
31	2B		G53-1542-03	PACKING (PHONE JACK)	
32	1B		G53-1544-01	PACKING (CABINET)	
33	2A		G53-1548-02	GASKET	
35	2C,1D		H12-3112-05	PACKING FIXTURE	
36	3D		H13-1190-02	CARTON BOARD	
37	1D		H25-2341-04	PROTECTION BAG	
38	2D		H52-1829-22	ITEM CARTON CASE	
40	3C		J19-1584-05	HOLDER ACCESSORY	
41	3D		J29-0662-03	BRACKET ACCESSORY	
43	3A		K29-9262-01	KEY TOP	
A	2B		N67-2608-46	PAN HEAD SEMS SCREW	
B	2B,3B		N87-2606-46	BRAZIER HEAD TAPTITE SCREW	
C	1B,2B		N87-2614-46	BRAZIER HEAD TAPTITE SCREW	
45	3C		N99-0395-05	SCREW SET ACCESSORY	
47	3A		T07-0739-05	SPEAKER	
48	2C		T91-0624-05	MICROPHONE ACCESSORY	
<b>DISPLAY UNIT (X54-3430-20)</b>					
D2-5			B30-2205-05	LED (YG)	
D19-26			B30-2205-05	LED (YG)	
D28-31			B30-2205-05	LED (YG)	

Ref. No.	Address	New parts	Parts No.	Description	Destination
C4			CC73GCH1H101J	CHIP C 100PF J	
C6			CK73GB1H103K	CHIP C 0.010UF K	
C15,16			CC73GCH1H101J	CHIP C 100PF J	
C18			CK73FB1A105K	CHIP C 1.0UF K	
C19			CK73GB1H681K	CHIP C 680PF K	
C22,23			CK73GB1H102K	CHIP C 1000PF K	
C24			CK73GB1H103K	CHIP C 0.010UF K	
C25			CK73GB1H102K	CHIP C 1000PF K	
C27,28			CK73GB1H102K	CHIP C 1000PF K	
C30			CK73GB1H103K	CHIP C 0.010UF K	
C31-33			CK73GB1H102K	CHIP C 1000PF K	
CN1			E40-6005-05	FLAT CABLE CONNECTOR	
J1			E08-0877-05	MODULAR JACK	
L1			L92-0138-05	FERRITE CHIP	
CP1			R90-0724-05	MULTI-COMP 1K X4	
R4-9			RK73GB1J102J	CHIP R 1.0K J 1/16W	
R10,11			RK73GB1J272J	CHIP R 2.7K J 1/16W	
R21-23			RK73GB1J103J	CHIP R 10K J 1/16W	
R24			RK73GB1J474J	CHIP R 470K J 1/16W	
R25			RK73GB1J473J	CHIP R 47K J 1/16W	
R26			RK73GB1J392J	CHIP R 3.9K J 1/16W	
R33			RK73FB2A560J	CHIP R 56 J 1/10W	
R34			RK73GB1J101J	CHIP R 100 J 1/16W	
R36			RK73FB2A560J	CHIP R 56 J 1/10W	
R37			RK73GB1J100J	CHIP R 10 J 1/16W	
R38,39			RK73FB2A390J	CHIP R 39 J 1/10W	
R40			RK73FB2A473J	CHIP R 47K J 1/10W	
D17			MA2S111	DIODE	
D18			HSB123	DIODE	
D27			DA221	DIODE	
IC2			LC75834W	MOS IC	
Q6			KRC102S	DIGITAL TRANSISTOR	
Q9			2SB1132(Q,R)	TRANSISTOR	
Q10			KRA225S	DIGITAL TRANSISTOR	
Q11			RN47A4	TRANSISTOR	
<b>TX-RX UNIT (X57-6710-XX) -21 : K -22 : K2 -23 : K3</b>					
C10			CK73GB1H102K	CHIP C 1000PF K	
C13-26			CK73GB1H471K	CHIP C 470PF K	
C28			CK73GB1H221K	CHIP C 220PF K	
C29			CK73GB1H471K	CHIP C 470PF K	
C30			CK73GB1H102K	CHIP C 1000PF K	
C32			CK73GB1H102K	CHIP C 1000PF K	
C33			CK73GB1H471K	CHIP C 470PF K	
C34			C92-0721-05	CHIP-ELE 330UF 25WV	
C35-38			CK73GB1H471K	CHIP C 470PF K	
C39,40			CK73GB1C104K	CHIP C 0.10UF K	
C41			C92-0795-05	CHIP-TAN 22UF 10WV	
C42			CK73GB1H103K	CHIP C 0.010UF K	
C43-45			C92-0795-05	CHIP-TAN 22UF 10WV	
C48			CK73GB1C473K	CHIP C 0.047UF K	K
C48-50			CK73GB1H103K	CHIP C 0.010UF K	K2,K3

## PARTS LIST

TX-RX UNIT (X57-6710-XX)

Ref. No.	Address	New parts	Parts No.	Description	Desti-nation	Ref. No.	Address	New parts	Parts No.	Description	Desti-nation
C49,50			CK73GB1H103K	CHIP C 0.010UF K	K	C263,264			CK73GB1C333K	CHIP C 0.033UF K	
C51			C92-0560-05	CHIP-TAN 10UF 6.3WV		C265,266			CK73GB1C104K	CHIP C 0.10UF K	
C52,53			CK73GB1H471K	CHIP C 470PF K		C267			CK73GB1A474K	CHIP C 0.47UF K	
C54,55			CK73GB1C104K	CHIP C 0.10UF K		C268			CK73GB1C104K	CHIP C 0.10UF K	
C56			CK73GB1H471K	CHIP C 470PF K		C269			CK73GB1A105K	CHIP C 1.0UF K	
C61			CK73GB1H471K	CHIP C 470PF K		C270			C92-0507-05	CHIP-TAN 4.7UF 6.3WV	
C66			CK73GB1H471K	CHIP C 470PF K		C271			CK73GB1H332K	CHIP C 3300PF K	
C72			CK73GB1H471K	CHIP C 470PF K		C272			CK73GB1H102K	CHIP C 1000PF K	
C77			CK73GB1H471K	CHIP C 470PF K		C273			CK73GB1A105K	CHIP C 1.0UF K	
C78			CK73GB1H102K	CHIP C 1000PF K		C274			CK73FB1C224K	CHIP C 0.22UF K	
C82			CK73GB1H471K	CHIP C 470PF K		C275			CK73GB1A105K	CHIP C 1.0UF K	
C83			CK73GB1C104K	CHIP C 0.10UF K		C276,277			CK73GB1H471K	CHIP C 470PF K	
C87			CC73GCH1H180J	CHIP C 18PF J		C278			CK73GB1C104K	CHIP C 0.10UF K	
C88,89			CC73GCH1H060B	CHIP C 6.0PF B		C279			C92-0516-05	CHIP-TAN 4.7UF 16WV	
C90			CC73GCH1H180J	CHIP C 18PF J		C280			C92-0040-05	CHIP-ELE 47UF 16WV	
C97,98			CK73GB1H471K	CHIP C 470PF K		C281			CK73GB1H471K	CHIP C 470PF K	
C101			CK73GB1H471K	CHIP C 470PF K		C282			C92-0722-05	CHIP-ELE 470UF 16WV	
C102			CK73GB1C104K	CHIP C 0.10UF K		C283			CK73GB1H102K	CHIP C 1000PF K	
C103			CK73GB1H102K	CHIP C 1000PF K		C301			C92-0507-05	CHIP-TAN 4.7UF 6.3WV	
C104			CK73GB1C104K	CHIP C 0.10UF K		C302			CK73GB1H102K	CHIP C 1000PF K	K,K2
C151			CK73GB1H182K	CHIP C 1800PF K		C302,303			CK73GB1H102K	CHIP C 1000PF K	K3
C152			CK73GB1H392K	CHIP C 3900PF K		C303			CK73GB1H472K	CHIP C 4700PF K	K,K2
C161			CK73GB1H102K	CHIP C 1000PF K		C304,305			CC73GCH1H121J	CHIP C 120PF J	K3
C162			C92-0507-05	CHIP-TAN 4.7UF 6.3WV		C304,305			CC73GCH1H221J	CHIP C 220PF J	K,K2
C163			CK73GB1H471K	CHIP C 470PF K		C306			CK73GB1H102K	CHIP C 1000PF K	
C164			C92-0560-05	CHIP-TAN 10UF 6.3WV		C307			CK73GB1E223K	CHIP C 0.022UF K	
C201			CK73GB1C104K	CHIP C 0.10UF K		C308			CK73GB1H102K	CHIP C 1000PF K	
C202			CK73GB1H471K	CHIP C 470PF K		C309			CK73GB1E223K	CHIP C 0.022UF K	
C203			CK73GB1C273K	CHIP C 0.027UF K		C310			CK73FB1C334K	CHIP C 0.33UF K	
C204			C92-0514-05	CHIP-TAN 2.2UF 10WV		C311,312			CK73GB1C104K	CHIP C 0.10UF K	
C205			CK73GB1C104K	CHIP C 0.10UF K		C313			C92-0662-05	CHIP-TAN 15UF 6.3WV	
C206			CK73GB1H102K	CHIP C 1000PF K		C314			CK73GB1H103K	CHIP C 0.010UF K	
C207			CK73GB1C223K	CHIP C 0.022UF K		C315-318			CK73GB1C104K	CHIP C 0.10UF K	
C208			CK73GB1H103K	CHIP C 0.010UF K		C319			CC73GCH1H101J	CHIP C 100PF J	
C210			CK73GB1C104K	CHIP C 0.10UF K		C321			CC73GCH1H330J	CHIP C 33PF J	
C211			CK73GB1H821K	CHIP C 820PF K		C322			CC73GCH1H560J	CHIP C 56PF J	
C212			CK73GB1H122K	CHIP C 1200PF K		C323			CC73GCH1H271J	CHIP C 270PF J	
C213			CK73GB1H332K	CHIP C 3300PF K		C324			CK73GB1H103K	CHIP C 0.010UF K	
C214			CC73GCH1H151J	CHIP C 150PF J		C326			CK73GB1H103K	CHIP C 0.010UF K	
C215			CK73GB1C104K	CHIP C 0.10UF K		C351			CC73GCH1H330J	CHIP C 33PF J	
C217,218			C92-0560-05	CHIP-TAN 10UF 6.3WV		C353			CK73GB1H103K	CHIP C 0.010UF K	
C220			C92-0507-05	CHIP-TAN 4.7UF 6.3WV		C354			CC73GCH1H060B	CHIP C 6.0PF B	
C221			CK73GB1C104K	CHIP C 0.10UF K		C355			CC73GCH1H180J	CHIP C 18PF J	
C225			C92-0004-05	CHIP-TAN 1.0UF 16WV		C356			CC73GCH1H020B	CHIP C 2.0PF B	
C226			CK73GB1H472K	CHIP C 4700PF K		C357			CK73GB1H103K	CHIP C 0.010UF K	
C227			CK73GB1E103K	CHIP C 0.010UF K		C358			CK73GB1H471K	CHIP C 470PF K	
C228			C92-0560-05	CHIP-TAN 10UF 6.3WV		C359			CC73GCH1H120J	CHIP C 12PF J	
C229			C92-0507-05	CHIP-TAN 4.7UF 6.3WV		C360			CC73GCH1H080B	CHIP C 8.0PF B	
C230			CK73GB1C104K	CHIP C 0.10UF K		C361,362			CK73GB1H471K	CHIP C 470PF K	
C231,232			CK73GB1H471K	CHIP C 470PF K		C363			CK73GB1H103K	CHIP C 0.010UF K	
C233			C92-0507-05	CHIP-TAN 4.7UF 6.3WV		C364			CK73GB1H471K	CHIP C 470PF K	
C250			CK73GB1C104K	CHIP C 0.10UF K		C366			CK73GB1C104K	CHIP C 0.10UF K	
C251			C92-0714-05	CHIP-TAN 4.7UF 6.3WV		C367			CC73GCH1H470J	CHIP C 47PF J	K2
C252			CC73GCH1H390J	CHIP C 39PF J		C367			CK73GB1H471K	CHIP C 470PF K	K,K3
C253,254			CK73GB1A105K	CHIP C 1.0UF K		C368			CC73GCH1H070B	CHIP C 7.0PF B	
C255			CK73GB1H822K	CHIP C 8200PF K		C369			CC73GCH1H060B	CHIP C 6.0PF B	K2
C256			CK73GB1E183K	CHIP C 0.018UF K		C369			CC73GCH1H1R5B	CHIP C 1.5PF B	K
C257			CK73GB1C393K	CHIP C 0.039UF K		C370			CK73GB1H471K	CHIP C 470PF K	
C258-261			CK73GB1H103J	CHIP C 0.010UF J		C371			CC73GCH1HOR5B	CHIP C 0.5PF B	
C262			CK73GB1H471K	CHIP C 470PF K		C372			CC73GCH1H150J	CHIP C 15PF J	

## PARTS LIST

## TX-RX UNIT (X57-6710-XX)

Ref. No.	Address	New parts	Parts No.	Description	Destination	Ref. No.	Address	New parts	Parts No.	Description	Destination
C373			CC73GCH1H080B	CHIP C 8.0PF B	K3	C439			CC73GCH1H020B	CHIP C 2.0PF B	K2
C373			CC73GCH1H090B	CHIP C 9.0PF B	K	C439			CC73GCH1H030B	CHIP C 3.0PF B	K
C373,374			CC73GCH1H070B	CHIP C 7.0PF B	K2	C440			CC73GCH1H030B	CHIP C 3.0PF B	K2,K3
C374			CC73GCH1H070B	CHIP C 7.0PF B	K,K3	C440			CC73GCH1H040B	CHIP C 4.0PF B	K
C375-380			CK73GB1H471K	CHIP C 470PF K		C441			CC73GCH1H0R3B	CHIP C 0.3PF B	
C381			CC73GCH1H060B	CHIP C 6.0PF B	K2	C442			C92-0560-05	CHIP-TAN 10UF 6.3WV	
C381			CC73GCH1H070B	CHIP C 7.0PF B	K,K3	C444			CK73GB1H471K	CHIP C 470PF K	
C382			CK73GB1H471K	CHIP C 470PF K		C448,449			CK73GB1H471K	CHIP C 470PF K	
C383			CC73GCH1H0R5B	CHIP C 0.5PF B		C450			C92-0568-05	CHIP-TAN 22UF 10WV	
C384			CC73GCH1H050B	CHIP C 5.0PF B	K2	C451,452			CK73GB1H471K	CHIP C 470PF K	
C384			CC73GCH1H070B	CHIP C 7.0PF B	K,K3	C454			CC73GCH1H060B	CHIP C 6.0PF B	
C385			CK73GB1H471K	CHIP C 470PF K		C455			CC73GCH1H020B	CHIP C 2.0PF B	
C386			CC73GCH1HR75B	CHIP C 0.75PF B	K,K3	C456			CC73GCH1H040B	CHIP C 4.0PF B	
C386			CC73GCH1H0R5B	CHIP C 0.5PF B	K2	C461			CK73GB1H471K	CHIP C 470PF K	
C388			CC73GCH1H030B	CHIP C 3.0PF B	K2	C463,464			CK73GB1H471K	CHIP C 470PF K	
C388			CC73GCH1H060B	CHIP C 6.0PF B	K,K3	C466			CC73GCH1H050B	CHIP C 5.0PF B	
C389			CK73GB1H103K	CHIP C 0.010UF K		C467			CK73GB1H471K	CHIP C 470PF K	
C390			CC73GCH1H050B	CHIP C 5.0PF B	K2	C501			CK73GB1H471K	CHIP C 470PF K	
C390			CC73GCH1H080B	CHIP C 8.0PF B	K,K3	C502			CC73GCH1H030B	CHIP C 3.0PF B	K,K2
C391			CK73GB1H471K	CHIP C 470PF K		C502			CC73GCH1H050B	CHIP C 5.0PF B	K3
C401-403			CC73GCH1H101J	CHIP C 100PF J		C504,505			CK73GB1H471K	CHIP C 470PF K	
C404			C92-0662-05	CHIP-TAN 15UF 6.3WV		C507			CK73GB1H471K	CHIP C 470PF K	
C406			CK73GB1H102K	CHIP C 1000PF K		C509			CC73GCH1H040B	CHIP C 4.0PF B	
C408			CC73GCH1H220J	CHIP C 22PF J		C510-515			CK73GB1H471K	CHIP C 470PF K	
C409			CK73GB1C104K	CHIP C 0.10UF K		C516			CC73GCH1H030B	CHIP C 3.0PF B	
C410			C92-0560-05	CHIP-TAN 10UF 6.3WV		C517			CK73GB1H471K	CHIP C 470PF K	
C411			CK73GB1C104K	CHIP C 0.10UF K		C518			C92-0040-05	CHIP-ELE 47UF 16WV	
C412			C92-0560-05	CHIP-TAN 10UF 6.3WV		C520,521			CK73GB1H471K	CHIP C 470PF K	
C413			CK73GB1H103K	CHIP C 0.010UF K		C522			CK73GB1C104K	CHIP C 0.10UF K	
C414			CK73GB1C104K	CHIP C 0.10UF K		C523			CC73FCH1H120J	CHIP C 12PF J	K2
C416,417			CK73GB1H471K	CHIP C 470PF K		C523			CC73FCH1H270J	CHIP C 27PF J	K3
C418			CK73GB1H102K	CHIP C 1000PF K		C523			CC73FCH1H470J	CHIP C 47PF J	K
C421,422			CK73GB1H471K	CHIP C 470PF K		C524			CC73FCH1H080D	CHIP C 8.0PF D	K
C423			C92-0555-05	CHIP-TAN 0.047UF 35WV		C524			CC73FCH1H100D	CHIP C 10PF D	K2,K3
C424			C92-0543-05	CHIP-TAN 3.3UF 10WV		C526			CC73FCH1H090D	CHIP C 9.0PF D	
C425			C92-0001-05	CHIP C 0.1UF 35WV		C527			CC73FCH1H120J	CHIP C 12PF J	K
C426			CC73GCH1H050B	CHIP C 5.0PF B	K2	C527			CC73FCH1H150J	CHIP C 15PF J	K2,K3
C426			CC73GCH1H080B	CHIP C 8.0PF B	K3	C528			CC73FCH1H470J	CHIP C 47PF J	K,K3
C426			CC73GCH1H180J	CHIP C 18PF J	K	C528,529			CC73FCH1H470J	CHIP C 47PF J	K2
C427			CC73GCH1H040B	CHIP C 4.0PF B	K2	C532			CK73GB1H471K	CHIP C 470PF K	
C427			CC73GCH1H070B	CHIP C 7.0PF B	K3	C534			CK73FB1H471K	CHIP C 470PF K	
C427			CC73GCH1H080B	CHIP C 8.0PF B	K	C535			CK73GB1H221K	CHIP C 220PF K	
C428			CK73GB1H471K	CHIP C 470PF K		C536			CK73GB1H471K	CHIP C 470PF K	
C429			CC73GCH1H010B	CHIP C 1.0PF B	K	C537			C92-0719-05	CHIP-ELE 47UF 25WV	
C429,430			CC73GCH1H020B	CHIP C 2.0PF B	K2,K3	C538			CK73FB1C474K	CHIP C 0.47UF K	
C430			CC73GCH1H060B	CHIP C 6.0PF B	K	C539			CK73FB1H471K	CHIP C 470PF K	
C431			CC73GCH1H030B	CHIP C 3.0PF B	K2,K3	C540			C93-0558-05	CHIP C 8.0PF D	K3
C431			CC73GCH1H050B	CHIP C 5.0PF B	K	C540			C93-0567-05	CHIP C 39PF J	K2
C432			CC73GCH1H0R5B	CHIP C 0.5PF B		C540			C93-0568-05	CHIP C 47PF J	K
C433			CK73GB1H471K	CHIP C 470PF K		C541			C93-0559-05	CHIP C 9.0PF D	K2
C434			CC73GCH1H040B	CHIP C 4.0PF B	K2	C541			C93-0562-05	CHIP C 15PF J	K3
C434			CC73GCH1H050B	CHIP C 5.0PF B	K3	C541			C93-0566-05	CHIP C 33PF J	K
C434			CC73GCH1H080B	CHIP C 8.0PF B	K	C543			C93-0599-05	CHIP C 470PF K	
C435			CC73GCH1H030B	CHIP C 3.0PF B	K2	C545			C93-0558-05	CHIP C 8.0PF D	K2
C435			CC73GCH1H060B	CHIP C 6.0PF B	K,K3	C545			C93-0560-05	CHIP C 10PF D	K
C436			CC73GCH1H0R5B	CHIP C 0.5PF B		C548			C93-0562-05	CHIP C 15PF J	K2
C437			CK73GB1H471K	CHIP C 470PF K		C548,549			C93-0566-05	CHIP C 33PF J	K,K3
C438			CC73GCH1H010B	CHIP C 1.0PF B	K	C549			C93-0562-05	CHIP C 15PF J	K2
C438			CC73GCH1H1R5B	CHIP C 1.5PF B	K2	C550,551			CM73F2H300J	CHIP C 30PF J	
C438,439			CC73GCH1H020B	CHIP C 2.0PF B	K3	C555			CK73FB1C474K	CHIP C 0.47UF K	



## PARTS LIST

TX-RX UNIT (X57-6710-XX)

Ref. No.	Address	New parts	Parts No.	Description	Desti-nation	Ref. No.	Address	New parts	Parts No.	Description	Desti-nation
C556			C93-0599-05	CHIP C 470PF K		L354,355			L34-4605-05	AIR-CORE COIL	K3
C559			CK73GB1H103K	CHIP C 0.010UF K		L355			L34-4604-05	AIR-CORE COIL	K2
C560			CK73GB1H471K	CHIP C 470PF K		L356			L40-1875-92	SMALL FIXED INDUCTOR (18NH)	K,K2
C564			CM73F2H010C	CHIP C 1.0PF C	K2	L356			L40-2275-92	SMALL FIXED INDUCTOR (22NH)	K3
C564			CM73F2H090D	CHIP C 9.0PF D	K	L357			L40-3975-92	SMALL FIXED INDUCTOR (39NH)	
C564			CM73F2H200J	CHIP C 20PF J	K3	L358			L34-4603-05	AIR-CORE COIL	K2
C565			CM73F2H030D	CHIP C 3.0PF D	K	L358-361			L34-4604-05	AIR-CORE COIL	K
C565			CM73F2H040D	CHIP C 4.0PF D	K2	L358,359			L34-4605-05	AIR-CORE COIL	K3
C567			CM73F2H080D	CHIP C 8.0PF D	K2	L359-361			L34-4604-05	AIR-CORE COIL	K2
C567			CM73F2H090D	CHIP C 9.0PF D	K	L360,361			L34-4604-05	AIR-CORE COIL	K3
C567			CM73F2H120J	CHIP C 12PF J	K3	L403			L41-1005-08	SMALL FIXED INDUCTOR	
C570			C93-0599-05	CHIP C 470PF K		L404			L92-0442-05	FERRITE CHIP	
C571			CK73GB1H471K	CHIP C 470PF K		L405			L92-0443-05	FERRITE CHIP	
C572,573			CK73GB1H103K	CHIP C 0.010UF K		L406,407			L40-2785-92	SMALL FIXED INDUCTOR (270NH)	K2,K3
C574			CK73GB1H102K	CHIP C 1000PF K		L406,407			L40-4791-86	SMALL FIXED INDUCTOR (4.7UH)	K
C575			CK73GB1H471K	CHIP C 470PF K		L408			L40-2778-67	SMALL FIXED INDUCTOR (27NH)	K
C576			CK73GB1H221K	CHIP C 220PF K		L408			L40-3978-67	SMALL FIXED INDUCTOR (39NH)	K2
C601			CC73GCH1H030B	CHIP C 3.0PF B	K2	L408			L40-5678-67	SMALL FIXED INDUCTOR (56NH)	K3
C601			CC73GCH1H050B	CHIP C 5.0PF B	K3	L409			L40-1885-92	SMALL FIXED INDUCTOR (180NH)	K2
C602			C93-0560-05	CHIP C 10PF D	K3	L409-412			L40-2785-92	SMALL FIXED INDUCTOR (270NH)	K3
C602			C93-0599-05	CHIP C 470PF K	K,K2	L409,410			L40-4791-86	SMALL FIXED INDUCTOR (4.7UH)	K
C603			CC73GCH1H0R5B	CHIP C 0.5PF B		L410-412			L40-2785-92	SMALL FIXED INDUCTOR (270NH)	K2
C604			CC73GCH1H010B	CHIP C 1.0PF B	K,K2	L411,412			L40-2702-86	SMALL FIXED INDUCTOR (27UH)	K
C604			CC73GCH1H020B	CHIP C 2.0PF B	K3	L413			L40-2778-67	SMALL FIXED INDUCTOR (27NH)	K
C605			C93-0552-05	CHIP C 2.0PF C	K2	L413			L40-3378-67	SMALL FIXED INDUCTOR (33NH)	K2
C605			C93-0556-05	CHIP C 6.0PF D	K,K3	L413			L40-4778-67	SMALL FIXED INDUCTOR (47NH)	K3
C607			CC73GCH1H0R5B	CHIP C 0.5PF B		L414			L40-1885-92	SMALL FIXED INDUCTOR (180NH)	K2,K3
C608			CC73GCH1H020B	CHIP C 2.0PF B	K3	L414,415			L40-2702-86	SMALL FIXED INDUCTOR (27UH)	K
C608			CC73GCH1H030B	CHIP C 3.0PF B	K,K2	L415			L40-2785-92	SMALL FIXED INDUCTOR (270NH)	K2,K3
C610			C93-0555-05	CHIP C 5.0PF C	K2	L416,417			L92-0443-05	FERRITE CHIP	
C610			C93-0558-05	CHIP C 8.0PF D	K	L418			L41-2775-06	SMALL FIXED INDUCTOR	
C610			C93-0560-05	CHIP C 10PF D	K3	L420			L41-2775-06	SMALL FIXED INDUCTOR	
C611			C93-0553-05	CHIP C 3.0PF C	K2,K3	L501			L41-1575-06	SMALL FIXED INDUCTOR	
C611			C93-0555-05	CHIP C 5.0PF C	K	L502			L41-2275-08	SMALL FIXED INDUCTOR	
C613,614			CK73GB1H471K	CHIP C 470PF K		L503			L41-3363-08	SMALL FIXED INDUCTOR	
TC352			C05-0400-05	CERAMIC TRIMMER CAP (3PF)	K3	L504			L41-1075-08	SMALL FIXED INDUCTOR	
TC352,353			C05-0399-05	CERAMIC TRIMMER CAP (6PF)	K,K2	L505			L34-4602-05	AIR-CORE COIL	K2
TC353			C05-0399-05	CERAMIC TRIMMER CAP (6PF)	K3	L505			L34-4603-05	AIR-CORE COIL	K,K3
TC401			C05-0245-05	CERAMIC TRIMMER CAP (10PF)	K3	L506			L34-4607-05	AIR-CORE COIL	
TC401,402			C05-0245-05	CERAMIC TRIMMER CAP (10PF)	K,K2	L507			L34-4602-05	AIR-CORE COIL	
TC402			C05-0399-05	CERAMIC TRIMMER CAP (6PF)	K3	L508			L34-4694-05	AIR-CORE COIL	
J1			E11-0425-05	3.5D PHONE JACK (3P)		L509			L34-4667-05	AIR-CORE COIL	
CN1			E40-6268-05	FLAT CABLE CONNECTOR		L601			L34-4669-05	AIR-CORE COIL	
CN2			E40-5702-05	PIN ASSY		L602,603			L34-4694-05	AIR-CORE COIL	
CN3			E40-6292-05	PIN ASSY		L604			L34-4667-05	AIR-CORE COIL	
CN4			E40-5932-05	PIN ASSY SOCKET		X86			L77-1934-05	CRYSTAL RESONATOR (14.31818MHZ)	
CN5			E40-3246-05	PIN ASSY		X401			L77-1868-15	TCXO (16.8MHZ)	
CN800			E23-0486-05	TERMINAL		XF351			L71-0591-05	MCF (49.95MHZ)	
CF301			L72-0993-05	CERAMIC FILTER		R1			RK73GB1J101J	CHIP R 100 J 1/16W	
CF302			L72-0999-05	CERAMIC FILTER		R2			R92-1252-05	CHIP R 0 OHM J 1/16W	
L101			L92-0443-05	FERRITE CHIP		R3			RK73GB1J102J	CHIP R 1.0K J 1/16W	
L201			L92-0443-05	FERRITE CHIP		R4			RK73GB1J332J	CHIP R 3.3K J 1/16W	
L301			L34-4554-05	COIL		R5			RK73GB1J223J	CHIP R 22K J 1/16W	
L302			L41-3385-08	SMALL FIXED INDUCTOR		R31			RK73GB1J472J	CHIP R 4.7K J 1/16W	
L303,304			L40-3381-86	SMALL FIXED INDUCTOR (0.33UH)		R32			R92-1215-05	CHIP R 470 J 1/2W	
L351,352			L40-4785-85	SMALL FIXED INDUCTOR (0.47UH)		R33			RK73GB1J473J	CHIP R 47K J 1/16W	
L354			L34-4603-05	AIR-CORE COIL	K2	R34			RK73GB1J472J	CHIP R 4.7K J 1/16W	
L354,355			L34-4604-05	AIR-CORE COIL	K	R35			RK73GB1J473J	CHIP R 47K J 1/16W	
						R36			RK73GB1J152J	CHIP R 1.5K J 1/16W	



## PARTS LIST

### TX-RX UNIT (X57-6710-XX)

Ref. No.	Address	New parts	Parts No.	Description	Destination	Ref. No.	Address	New parts	Parts No.	Description	Destination
R37			RK73GB1J103J	CHIP R 10K J 1/16W		R222			RK73GB1J102J	CHIP R 1.0K J 1/16W	
R38			RK73GB1J334J	CHIP R 330K J 1/16W		R223			RK73GB1J472J	CHIP R 4.7K J 1/16W	
R39			RK73GB1J474J	CHIP R 470K J 1/16W		R224			RK73GB1J102J	CHIP R 1.0K J 1/16W	
R40			RK73GB1J394J	CHIP R 390K J 1/16W		R225			RK73GB1J154J	CHIP R 150K J 1/16W	
R41			RK73GB1J334J	CHIP R 330K J 1/16W		R226			RK73GB1J104J	CHIP R 100K J 1/16W	
R61			RK73GB1J471J	CHIP R 470 J 1/16W		R227			RK73GB1J223J	CHIP R 22K J 1/16W	
R62			RK73GB1J102J	CHIP R 1.0K J 1/16W		R228			RK73GB1J103J	CHIP R 10K J 1/16W	
R66,67			RK73GB1J473J	CHIP R 47K J 1/16W		R229			RK73GB1J684J	CHIP R 680K J 1/16W	
R68,69			RK73GB1J102J	CHIP R 1.0K J 1/16W		R230			RK73GB1J124J	CHIP R 120K J 1/16W	
R70			RK73GB1J473J	CHIP R 47K J 1/16W		R231			RK73GB1J683J	CHIP R 68K J 1/16W	
R71			RK73GB1J472J	CHIP R 4.7K J 1/16W		R232			RK73GB1J912J	CHIP R 9.1K J 1/16W	
R72			RK73GB1J105J	CHIP R 1.0M J 1/16W		R233			RK73GB1J682J	CHIP R 6.8K J 1/16W	
R73			RK73GB1J104J	CHIP R 100K J 1/16W		R249-251			RK73GB1J473J	CHIP R 47K J 1/16W	
R74			RK73GB1J473J	CHIP R 47K J 1/16W		R252			RK73GB1J474J	CHIP R 470K J 1/16W	
R75			RK73GB1J102J	CHIP R 1.0K J 1/16W		R253			R92-1252-05	CHIP R 0 OHM J 1/16W	
R76			RK73GH1J183D	CHIP R 18K D 1/16W		R254			RK73GB1J681J	CHIP R 680 J 1/16W	
R77			RK73GH1J134D	CHIP R 130K D 1/16W		R255,256			RK73GB1J562J	CHIP R 5.6K J 1/16W	
R78			RK73GB1J102J	CHIP R 1.0K J 1/16W		R257			RK73GB1J105J	CHIP R 1.0M J 1/16W	
R81			RK73GB1J473J	CHIP R 47K J 1/16W		R258			RK73GB1J272J	CHIP R 2.7K J 1/16W	
R82			R92-1252-05	CHIP R 0 OHM J 1/16W		R259			RK73GB1J123J	CHIP R 12K J 1/16W	
R86			R92-1252-05	CHIP R 0 OHM J 1/16W		R260			RK73GB1J224J	CHIP R 220K J 1/16W	
R87			RK73GB1J102J	CHIP R 1.0K J 1/16W		R261			RK73GB1J124J	CHIP R 120K J 1/16W	
R91,92			RK73GB1J102J	CHIP R 1.0K J 1/16W		R262			RK73GB1J183J	CHIP R 18K J 1/16W	
R93,94			RK73GB1J562J	CHIP R 5.6K J 1/16W		R263			RK73GH1J913D	CHIP R 91K D 1/16W	
R101,102			RK73GB1J473J	CHIP R 47K J 1/16W		R264			RK73GH1J124D	CHIP R 120K D 1/16W	
R103-106			RK73GB1J102J	CHIP R 1.0K J 1/16W		R265			RK73GH1J562D	CHIP R 5.6K D 1/16W	
R107,108			RK73GB1J473J	CHIP R 47K J 1/16W		R266			RK73GB1J562J	CHIP R 5.6K J 1/16W	
R109			RK73GB1J152J	CHIP R 1.5K J 1/16W		R267			R92-0670-05	CHIP R 0 OHM	
R110			RK73GB1J473J	CHIP R 47K J 1/16W		R268			RK73GB1J102J	CHIP R 1.0K J 1/16W	
R111			RK73GB1J102J	CHIP R 1.0K J 1/16W		R269			RK73GB1J823J	CHIP R 82K J 1/16W	
R112,113			RK73GB1J473J	CHIP R 47K J 1/16W		R270			RK73GB1J272J	CHIP R 2.7K J 1/16W	
R114-119			RK73GB1J102J	CHIP R 1.0K J 1/16W		R271			RK73GB1J561J	CHIP R 560 J 1/16W	
R120-123			R92-1252-05	CHIP R 0 OHM J 1/16W		R272			RK73GB1J152J	CHIP R 1.5K J 1/16W	
R124			RK73GB1J473J	CHIP R 47K J 1/16W		R273			RK73GB1J472J	CHIP R 4.7K J 1/16W	
R125-128			RK73GB1J102J	CHIP R 1.0K J 1/16W		R274,275			RK73GB1J153J	CHIP R 15K J 1/16W	
R129			R92-1252-05	CHIP R 0 OHM J 1/16W		R276			RK73GB1J473J	CHIP R 47K J 1/16W	
R130,131			RK73GB1J102J	CHIP R 1.0K J 1/16W		R277			RK73GB1J683J	CHIP R 68K J 1/16W	
R151			RK73GB1J103J	CHIP R 10K J 1/16W		R278			RK73GB1J123J	CHIP R 12K J 1/16W	
R152			RK73GB1J472J	CHIP R 4.7K J 1/16W		R279			RK73GB1J472J	CHIP R 4.7K J 1/16W	
R161			RK73GB1J122J	CHIP R 1.2K J 1/16W		R280			RK73GB1J391J	CHIP R 390 J 1/16W	
R162			RK73GB1J152J	CHIP R 1.5K J 1/16W		R281			R92-0670-05	CHIP R 0 OHM	
R163			RK73GB1J473J	CHIP R 47K J 1/16W		R301,302			RK73GB1J472J	CHIP R 4.7K J 1/16W	
R164-166			RK73GB1J102J	CHIP R 1.0K J 1/16W		R303			RK73GB1J223J	CHIP R 22K J 1/16W	
R201			RK73GB1J681J	CHIP R 680 J 1/16W		R304			RK73GB1J123J	CHIP R 12K J 1/16W	K3
R202			R92-0670-05	CHIP R 0 OHM		R304			RK73GB1J472J	CHIP R 4.7K J 1/16W	K,K2
R203			RK73GB1J104J	CHIP R 100K J 1/16W		R305			RK73GB1J182J	CHIP R 1.8K J 1/16W	K,K2
R204			RK73GB1J183J	CHIP R 18K J 1/16W		R305			RK73GB1J183J	CHIP R 18K J 1/16W	K3
R205			RK73GB1J821J	CHIP R 820 J 1/16W		R306			RK73GB1J224J	CHIP R 220K J 1/16W	K3
R206			RK73GB1J101J	CHIP R 100 J 1/16W		R306			RK73GB1J274J	CHIP R 270K J 1/16W	K,K2
R207			RK73GB1J754J	CHIP R 750K J 1/16W		R308			RK73GB1J334J	CHIP R 330K J 1/16W	
R208			RK73GB1J152J	CHIP R 1.5K J 1/16W		R309			RK73GB1J332J	CHIP R 3.3K J 1/16W	
R209			RK73GB1J244J	CHIP R 240K J 1/16W		R310			RK73GB1J102J	CHIP R 1.0K J 1/16W	
R211,212			RK73GB1J823J	CHIP R 82K J 1/16W		R311			RK73GB1J273J	CHIP R 27K J 1/16W	K2
R213			RK73GB1J334J	CHIP R 330K J 1/16W		R311			RK73GB1J333J	CHIP R 33K J 1/16W	K,K3
R214,215			RK73GB1J683J	CHIP R 68K J 1/16W		R312			RK73GB1J154J	CHIP R 150K J 1/16W	K2
R216			RK73GB1J274J	CHIP R 270K J 1/16W		R312			RK73GB1J473J	CHIP R 47K J 1/16W	K,K3
R217			RK73GB1J224J	CHIP R 220K J 1/16W		R313			RK73GB1J104J	CHIP R 100K J 1/16W	
R218			RK73GB1J823J	CHIP R 82K J 1/16W		R314			RK73GB1J222J	CHIP R 2.2K J 1/16W	
R219			RK73GB1J563J	CHIP R 56K J 1/16W		R315			RK73GB1J183J	CHIP R 18K J 1/16W	
R220,221			RK73GH1J153D	CHIP R 15K D 1/16W		R316			RK73GB1J223J	CHIP R 22K J 1/16W	

## PARTS LIST

TX-RX UNIT (X57-6710-XX)

Ref. No.	Address	New parts	Parts No.	Description	Destination	Ref. No.	Address	New parts	Parts No.	Description	Destination
R317-320			RK73GB1J103J	CHIP R 10K J 1/16W		R432			RK73GB1J102J	CHIP R 1.0K J 1/16W	
R321			RK73GB1J223J	CHIP R 22K J 1/16W		R433			RK73GB1J472J	CHIP R 4.7K J 1/16W	
R322			RK73GB1J101J	CHIP R 100 J 1/16W		R434			R92-1252-05	CHIP R 0 OHM J 1/16W	
R323			RK73GB1J154J	CHIP R 150K J 1/16W		R435			RK73GB1J101J	CHIP R 100 J 1/16W	
R324			R92-1252-05	CHIP R 0 OHM J 1/16W		R436			RK73GB1J124J	CHIP R 120K J 1/16W	
R325			RK73GB1J333J	CHIP R 33K J 1/16W		R439			RK73GB1J124J	CHIP R 120K J 1/16W	
R351			RK73GB1J471J	CHIP R 470 J 1/16W		R440			RK73GB1J101J	CHIP R 100 J 1/16W	
R352			RK73GB1J101J	CHIP R 100 J 1/16W		R441			RK73GB1J102J	CHIP R 1.0K J 1/16W	
R353			RK73GB1J104J	CHIP R 100K J 1/16W		R442			RK73GB1J101J	CHIP R 100 J 1/16W	
R354			RK73GB1J561J	CHIP R 560 J 1/16W		R443			RK73GB1J222J	CHIP R 2.2K J 1/16W	
R355			RK73GB1J681J	CHIP R 680 J 1/16W		R444			RK73GB1J102J	CHIP R 1.0K J 1/16W	
R358			RK73GB1J470J	CHIP R 47 J 1/16W		R445,446			R92-1252-05	CHIP R 0 OHM J 1/16W	
R359			RK73GB1J334J	CHIP R 330K J 1/16W		R501			RK73GB1J102J	CHIP R 1.0K J 1/16W	
R360			RK73GB1J474J	CHIP R 470K J 1/16W		R502			RK73GB1J472J	CHIP R 4.7K J 1/16W	
R361			RK73GB1J220J	CHIP R 22 J 1/16W		R506			RK73GB1J103J	CHIP R 10K J 1/16W	
R362			RK73GB1J474J	CHIP R 470K J 1/16W		R507			RK73GB1J470J	CHIP R 47 J 1/16W	
R363			RK73GB1J154J	CHIP R 150K J 1/16W		R509			RK73GB1J100J	CHIP R 10 J 1/16W	
R364			R92-1252-05	CHIP R 0 OHM J 1/16W		R511			RK73GB1J471J	CHIP R 470 J 1/16W	
R365,366			RK73GB1J104J	CHIP R 100K J 1/16W		R512			RK73GB1J332J	CHIP R 3.3K J 1/16W	
R367			RK73GB1J101J	CHIP R 100 J 1/16W		R513			RK73GB1J682J	CHIP R 6.8K J 1/16W	
R369			RK73GB1J151J	CHIP R 150 J 1/16W		R514			RK73FB2A470J	CHIP R 47 J 1/10W	K
R370			RK73GB1J474J	CHIP R 470K J 1/16W		R514			RK73FB2A560J	CHIP R 56 J 1/10W	K2,K3
R371			RK73GB1J394J	CHIP R 390K J 1/16W		R515			RK73GB1J100J	CHIP R 10 J 1/16W	
R372			RK73GB1J684J	CHIP R 680K J 1/16W		R516			RK73GB1J332J	CHIP R 3.3K J 1/16W	
R373			RK73GB1J184J	CHIP R 180K J 1/16W		R517			RK73GB1J100J	CHIP R 10 J 1/16W	
R374			RK73GB1J104J	CHIP R 100K J 1/16W		R518			RK73GB1J153J	CHIP R 15K J 1/16W	
R375			R92-1252-05	CHIP R 0 OHM J 1/16W		R519			RK73FB2A220J	CHIP R 22 J 1/10W	
R376			RK73GB1J104J	CHIP R 100K J 1/16W		R520			RK73GB1J333J	CHIP R 33K J 1/16W	
R377			R92-1252-05	CHIP R 0 OHM J 1/16W		R521			RK73GB1J101J	CHIP R 100 J 1/16W	
R378			RK73GB1J104J	CHIP R 100K J 1/16W		R522			R92-1217-05	CHIP R 0 OHM	
R380			RK73GB1J104J	CHIP R 100K J 1/16W		R524			RK73FB2A821J	CHIP R 820 J 1/10W	K
R381			RK73GB1J100J	CHIP R 10 J 1/16W	K3	R525			RK73EB2B5R6J	CHIP R 5.6 J 1/8W	K
R381			R92-1252-05	CHIP R 0 OHM J 1/16W	K,K2	R525			R92-0679-05	CHIP R 0 OHM	K2,K3
R401-403			RK73GB1J102J	CHIP R 1.0K J 1/16W		R526			RK73FB2A821J	CHIP R 820 J 1/10W	K
R404			RK73GB1J103J	CHIP R 10K J 1/16W		R527			RK73GB1J474J	CHIP R 470K J 1/16W	
R405			R92-1252-05	CHIP R 0 OHM J 1/16W		R528,529			RK73GB1J471J	CHIP R 470 J 1/16W	
R407			RK73GB1J152J	CHIP R 1.5K J 1/16W		R530			RK73GB1J821J	CHIP R 820 J 1/16W	
R408			RK73GB1J100J	CHIP R 10 J 1/16W		R531			RK73GB1J473J	CHIP R 47K J 1/16W	
R409			RK73GB1J104J	CHIP R 100K J 1/16W		R532,533			R92-1252-05	CHIP R 0 OHM J 1/16W	
R410,411			RK73GB1J103J	CHIP R 10K J 1/16W		R534			RK73GB1J473J	CHIP R 47K J 1/16W	K2,K3
R412			RK73GB1J123J	CHIP R 12K J 1/16W		R534			RK73GB1J683J	CHIP R 68K J 1/16W	K
R413			RK73GB1J103J	CHIP R 10K J 1/16W		R535			RK73GB1J563J	CHIP R 56K J 1/16W	
R414,415			R92-1252-05	CHIP R 0 OHM J 1/16W		R536			RK73EB2B100J	CHIP R 10 J 1/8W	
R416			RK73GB1J471J	CHIP R 470 J 1/16W		R537			RK73GB1J823J	CHIP R 82K J 1/16W	
R417			RK73GB1J224J	CHIP R 220K J 1/16W		R538			RK73GB1J473J	CHIP R 47K J 1/16W	K2,K3
R418,419			RK73GB1J102J	CHIP R 1.0K J 1/16W		R538			RK73GB1J563J	CHIP R 56K J 1/16W	K
R420			RK73GB1J222J	CHIP R 2.2K J 1/16W		R539			R92-1213-05	CHIP R 100 J 1/2W	
R421			RK73GB1J152J	CHIP R 1.5K J 1/16W		R601,602			RK73GB1J223J	CHIP R 22K J 1/16W	
R422			RK73GB1J103J	CHIP R 10K J 1/16W		R603			RK73GB1J473J	CHIP R 47K J 1/16W	
R423			RK73GB1J221J	CHIP R 220 J 1/16W	K	R605			RK73GB1J153J	CHIP R 15K J 1/16W	
R423			RK73GB1J271J	CHIP R 270 J 1/16W	K2	R606			RK73GB1J221J	CHIP R 220 J 1/16W	
R423			RK73GB1J331J	CHIP R 330 J 1/16W	K3	R822			R92-1215-05	CHIP R 470 J 1/2W	
R424			RK73GB1J151J	CHIP R 150 J 1/16W	K	R823			R92-0679-05	CHIP R 0 OHM	
R424			RK73GB1J221J	CHIP R 220 J 1/16W	K2	VR1			R12-6427-05	TRIMMING POT. (47K)	
R424			RK73GB1J271J	CHIP R 270 J 1/16W	K3	D1-11			DA221	DIODE	
R425,426			RK73GB1J473J	CHIP R 47K J 1/16W		D31			ZSH5MA27	SURGE ABSORBER	
R427			RK73GB1J104J	CHIP R 100K J 1/16W		D32			1812L110PR	VARIATOR	
R428			RK73GB1J473J	CHIP R 47K J 1/16W		D61			02DZ18(X,Y)	ZENER DIODE	
R429,430			RK73GB1J101J	CHIP R 100 J 1/16W		D201			DAN222	DIODE	
R431			RK73GB1J104J	CHIP R 100K J 1/16W							

# TK-8100H

## PARTS LIST

### TX-RX UNIT (X57-6710-XX)

Ref. No.	Address	New parts	Parts No.	Description	Destination	Ref. No.	Address	New parts	Parts No.	Description	Destination
D202			1SS372	DIODE		Q408			KRX102U	TRANSISTOR	
D251			MA742	DIODE		Q410,411			2SC5108(Y)	TRANSISTOR	
D301			MA742	DIODE		Q440			2SC4617(S)	TRANSISTOR	
D302,303			DAN222	DIODE		Q500			2SC5110(O)	TRANSISTOR	
D351-355			HVC350B	VARIABLE CAPACITANCE DIODE	K	Q501			2SC3356(R24)	TRANSISTOR	
D351-355			HVC355B	VARIABLE CAPACITANCE DIODE	K2	Q502			2SK2596	FET	
D351,352			HVC350B	VARIABLE CAPACITANCE DIODE	K3	Q503			PD55008TR	FET	
D353			HVC355B	VARIABLE CAPACITANCE DIODE	K3	Q504	2B		RD60HUF1-01	RF POWER FET	
D354,355			HVC350B	VARIABLE CAPACITANCE DIODE	K3	TH97,98			B57331V2104J	THERMISTOR	
D401			MA2S111	DIODE		TH301			B57331V2104J	THERMISTOR	
D402			HZU5ALL	DIODE		TH351		*	NCP18XW332J03	THERMISTOR	
D403-406			MA2S304	VARIABLE CAPACITANCE DIODE		TH401			NCP18XH103K03	THERMISTOR	K
D407			MA360	VARIABLE CAPACITANCE DIODE							
D408			MA2S111	DIODE							
D409			DAN235E	DIODE							
D502			DA221	DIODE							
D503			02DZ5.1(Y)	ZENER DIODE							
D601,602			MA4PH633	DIODE							
D604,605			XB15A709	DIODE							
D606,607			MA742	DIODE							
D608			1SS355	DIODE							
IC31			KIA7808AF	ANALOG IC							
IC32,33			NJM78L05UA	BI-POLAR IC							
IC34,35			PST9140NR	MOS IC							
IC66			AT24C64N10S118	ROM IC							
IC101			30622MAA-B76GP	MPU							
IC161			M62363FP	MOS IC							
IC201			NJM2100V	MOS IC							
IC202			NJM2904V	MOS IC							
IC203			NJM2902V	MOS IC							
IC251	2B		NJM2902V	MOS IC							
IC252			LA4600	AF POWER IC							
IC301			TK14489V	BI-POLAR IC							
IC401			MB15A02	MOS IC							
IC501			TA75W01FU	MOS IC							
Q1			2SK1824	FET							
Q31			2SA1641(S,T)	TRANSISTOR							
Q32			KRC102S	DIGITAL TRANSISTOR							
Q33			2SA1745(6,7)	TRANSISTOR							
Q34			KRC102S	DIGITAL TRANSISTOR							
Q35			KTA1664(Y)	TRANSISTOR							
Q36			KRC102S	DIGITAL TRANSISTOR							
Q61			KRC404RTK	DIGITAL TRANSISTOR							
Q71			KRC414RTK	DIGITAL TRANSISTOR							
Q86,87			2SK1824	FET							
Q201			2SC4919	TRANSISTOR							
Q202			2SJ243	FET							
Q251			2SC4617(S)	TRANSISTOR							
Q252,253			2SK1824	FET							
Q254			DTC363EU	DIGITAL TRANSISTOR							
Q255			KRC102S	DIGITAL TRANSISTOR							
Q301			2SC2412K	TRANSISTOR							
Q302			2SC4649(N,P)	TRANSISTOR							
Q351			2SC5108(Y)	TRANSISTOR							
Q352,353			3SK255	FET							
Q402			2SA1832(GR)	TRANSISTOR							
Q403			2SC4738(GR)	TRANSISTOR							
Q404			2SC4649(N,P)	TRANSISTOR							
Q405,406			2SK508NV(K52)	FET							
Q407			2SJ243	FET							

## EXPLODED VIEW

- A M2.6 x 8 : N67-2608-46
- B M2.6 x 6 (Br-Tap) : N87-2606-46
- C M2.6 x 14 (Br-Tap) : N87-2614-46

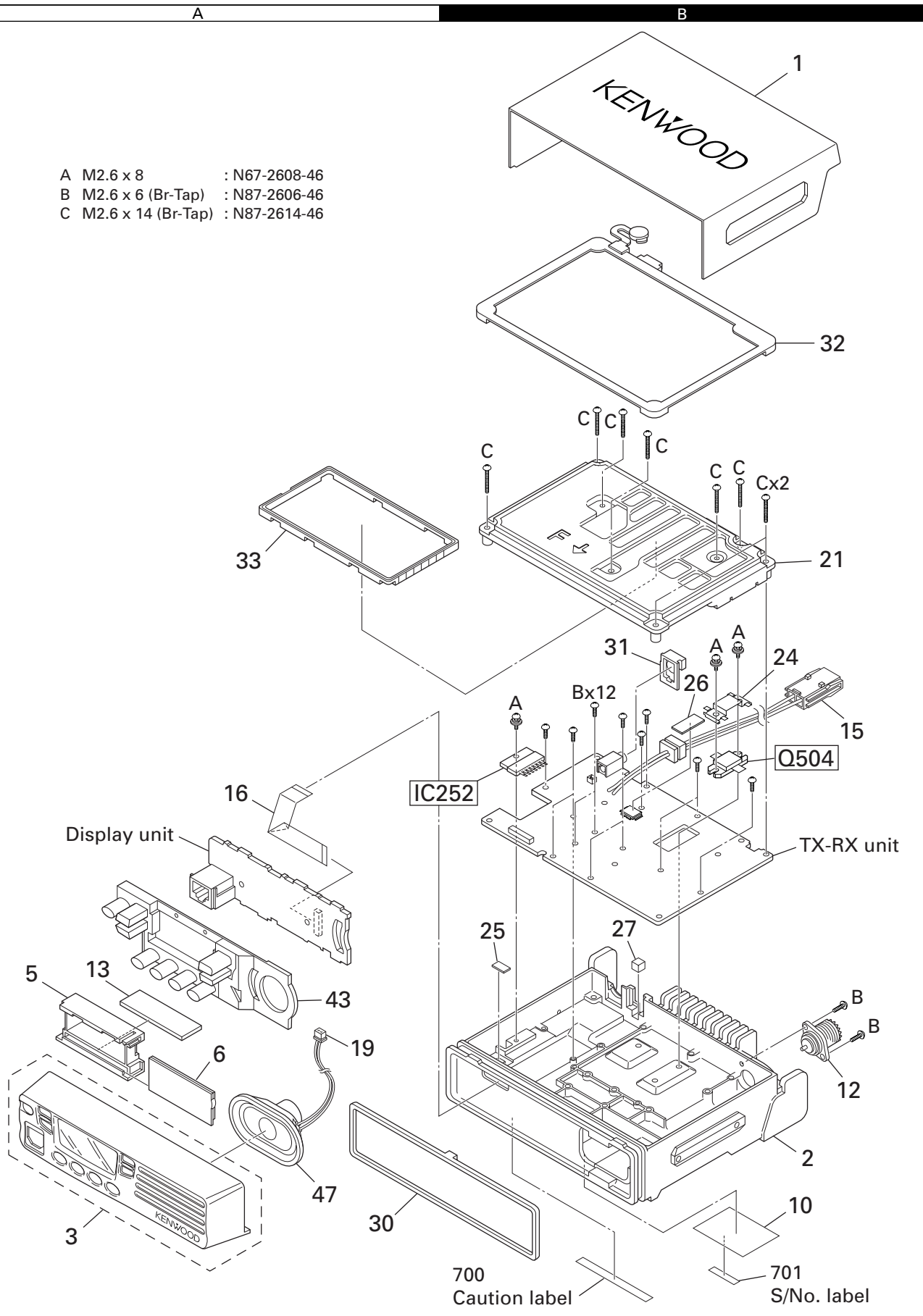

Parts with the exploded numbers larger than 700 are not supplied.

## PACKING

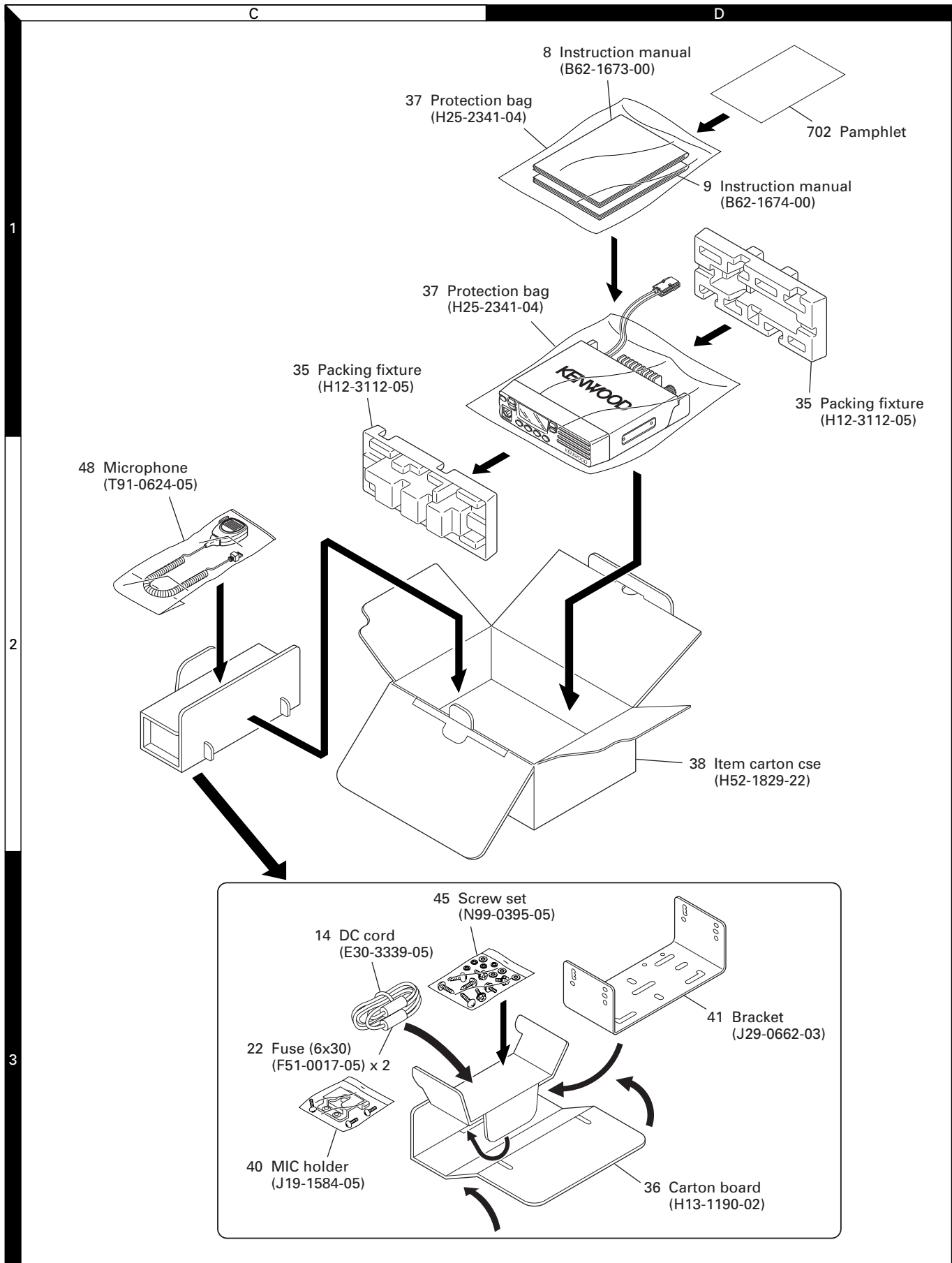

## ADJUSTMENT

### Test Equipment Required for Alignment

Test Equipment	Major Specifications	
1. Standard Signal Generator (SSG)	Frequency Range	400 to 520MHz
	Modulation	Frequency modulation and external modulation
	Output	-127dBm/0.1μV to greater than -7dBm/100mV
2. Power Meter	Input Impedance	50Ω
	Operation Frequency	400 to 520MHz or more
	Measurement Capability	Vicinity of 100W
3. Deviation Meter	Frequency Range	400 to 520MHz
4. Digital Volt Meter (DVM)	Measuring Range	1 to 20V DC
	Accuracy	High input impedance for minimum circuit loading
5. Oscilloscope		DC through 30MHz
6. High Sensitivity Frequency Counter	Frequency Range	10Hz to 1000MHz
	Frequency Stability	0.2ppm or less
7. Ammeter		20A
8. AF Volt Meter (AF VTVM)	Frequency Range	50Hz to 10kHz
	Voltage Range	1mV to 3V
9. Audio Generator (AG)	Frequency Range	20Hz to 20kHz or more
	Output	0 to 1V
10. Distortion Meter	Capability	3% or less at 1kHz
	Input Level	50mV to 10Vrms
11. 4Ω Dummy Load		Approx. 4Ω, 10W or more
12. Regulated Power Supply		13.6V, approx. 20A (adjustable from 9 to 17V) Useful if ammeter equipped
13. Spectrum Analyzer	Center frequency	50KHz to 600MHz
14. Tracking Generator	Output Voltage	100mV or more

### Test cable for microphone input (E30-3360-08)

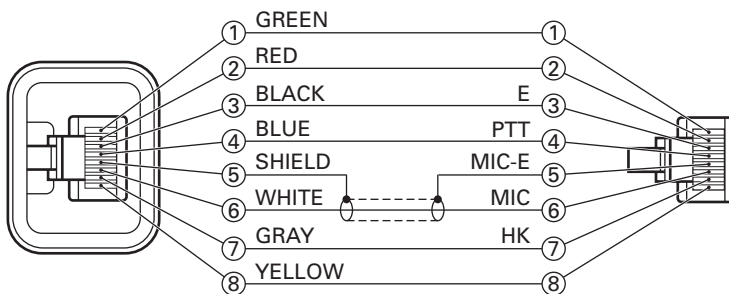

### MIC connector (Front view)

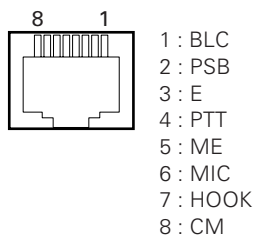

### Tuning cable (E30-3383-05)

Adapter cable (E30-3383-05) is required for injecting an audio if PC tuning is used. See "PC Mode" section for the connection.

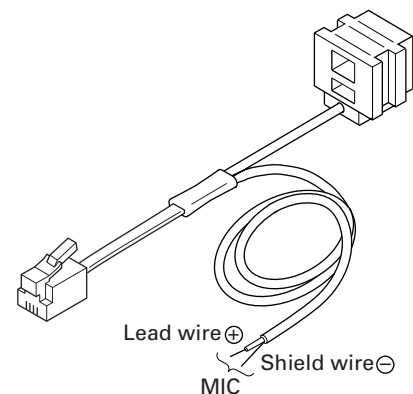

## ADJUSTMENT

### Adjustment Location

#### ■ Switch

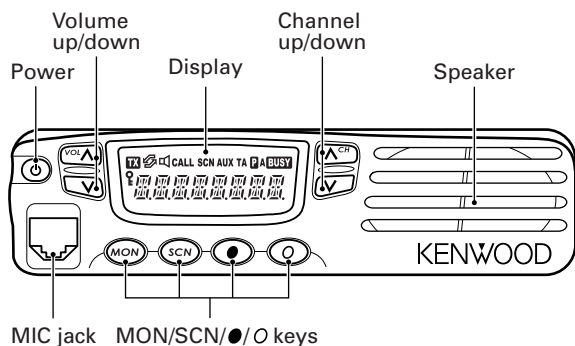

#### ■ Adjustment Points

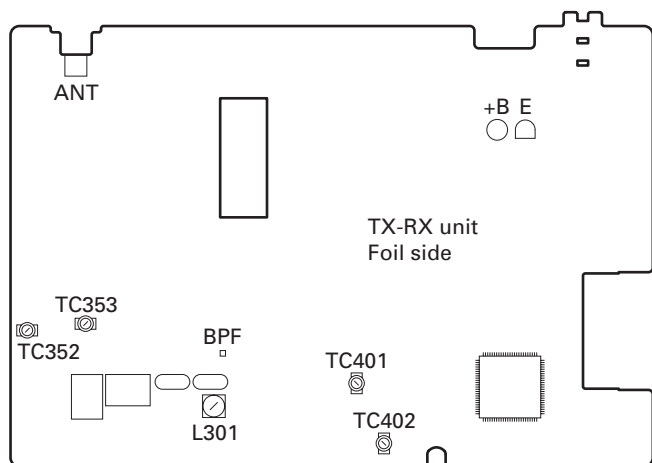
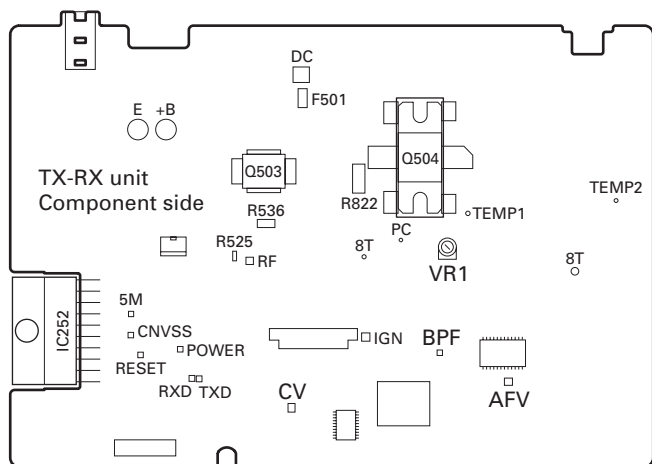

#### ■ Notes

##### • EEPROM

The tuning data (Deviation, Squelch, etc.) for the EEPROM, is stored in memory. When parts are changed, re-adjust the transceiver.

##### • AF PA IC (IC252)

How to mounting the IC252.

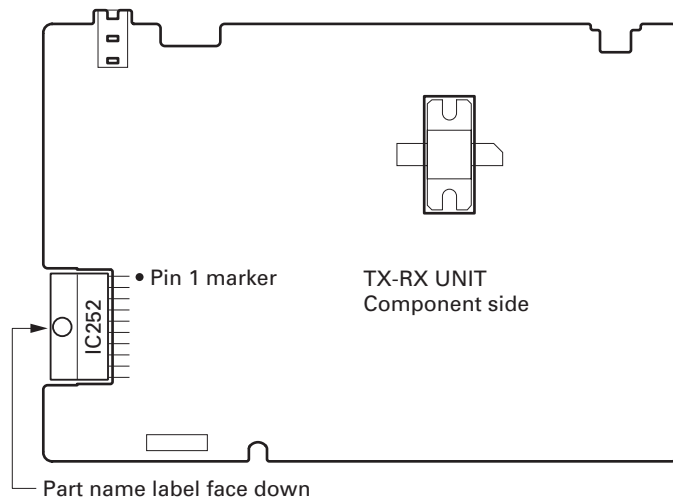

##### • Speaker Cable

The speaker cable should be formed before mounting the shield cover as below.

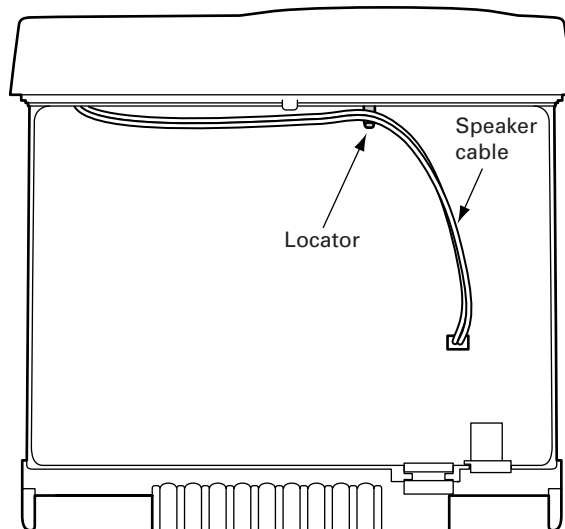

##### • Fuse

To mount the fuse, the cable terminal direction must be as follow.

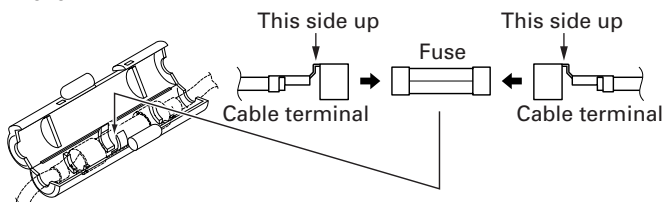



## ADJUSTMENT

### Test Frequency (MHz)

Channel	K		K2		K3	
	TX	RX	TX	RX	TX	RX
1 : Center	470.100	470.050	498.600	498.550	415.100	415.050
2 : Low	450.100	450.050	485.100	485.050	400.100	400.050
3 : High	489.900	489.950	511.900	511.950	429.900	429.950
4	470.000	470.000	498.500	498.500	415.000	415.000
5	470.200	470.200	498.700	498.700	415.200	415.200
6	470.400	470.400	498.900	498.900	415.400	415.400

### PCB Section

Item	Condition	Measurement		Adjustment		Specifications/ Remarks
		Test equipment	Terminal	Parts	Method	
1. Setting	1) Power supply voltage DC Power supply terminal : 13.6V					
2. VCO lock voltage*	1) CH : TX high	Digital voltmeter	CV	TC402	5.5V	±0.1V
	2) CH : RX high			TC401	5.5V	±0.1V
	3) CH : TX low				Check	0.7V or more
	4) CH : RX low					
3. IF coil	1) CH : RX center (Wide) 2) SSG output : -53dBm (501μV) Mod : 1kHz Dev : 3kHz	SSG Digital voltmeter	AFV	L301	3.25~3.35V (DC)	
4. RF bandpass filter	1) CH : RX center (Wide) CH : RX low (Wide) CH : RX high (Wide) 2) Tra generator output : -30dBm Connect the spectrum analyzer to BPF terminal	Tra generator Spectrum analyzer	ANT BPF	TC352 TC353	Adjust the BPF waveform to Fig. 1	

#### \* Adjustment of TX VCO lock voltage

1. Remove R525, F501, R536 and R822 (all on component side).
2. Remove PCB from chassis.
3. Transmit and check voltage at [CV] point.

**Warning :** Do not transmit if step "1." is not complete.

4. Adjust of voltage can be done by tuning TC402.

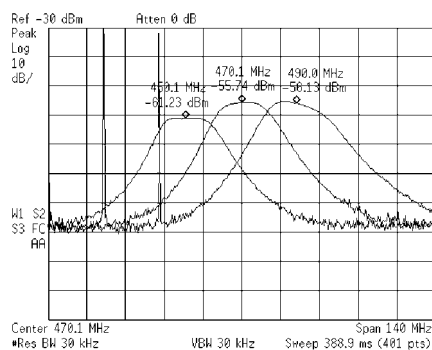

**K**

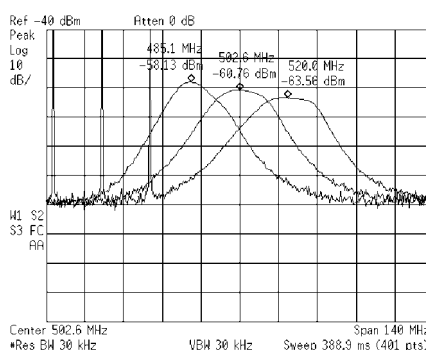

**K2**

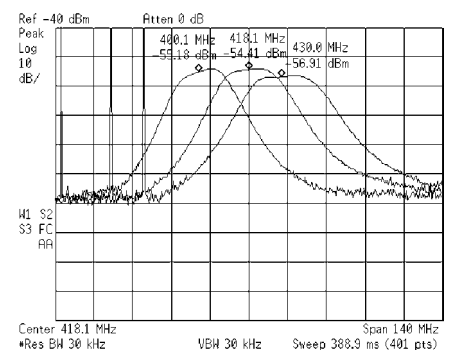

**K3**

**Fig. 1**

## ADJUSTMENT

## Receiver Section

Item	Condition	Measurement		Adjustment		Specifications/ Remarks
		Test equipment	Terminal	Parts	Method	
1. Seisitivity	1) CH : RX low (Wide/Narrow) CH : RX center (Wide/Narrow) CH : RX high (Wide/Narrow) 2) SSG output : -118dBm (0.28 $\mu$ V) (Wide) : -116dBm (0.35 $\mu$ V) (Narrow) Mod : 1kHz Dev : $\pm$ 3.0kHz (Wide) Dev : $\pm$ 1.5kHz (Narrow)	SSG Oscilloscope AF V.M Distortion meter	ANT EXT. SP		Check	SINAD : 12dB or higher
2. Squelch 9	1) CH : RX low (Wide) CH : RX center (Wide/Narrow) CH : RX high (Wide) 2) SSG output : -115dBm (0.4 $\mu$ V) (Wide) : -114dBm (0.45 $\mu$ V) (Narrow) Mod : 1kHz Dev : $\pm$ 3.0kHz (Wide) Dev : $\pm$ 1.5kHz (Narrow)			PC key	Adjust to open the squelch	
3. Squelch 1	1) CH : RX low (Wide) CH : RX center (Wide/Narrow) CH : RX high (Wide) 2) SSG output : -120dBm (0.22 $\mu$ V) (Wide) : -119dBm (0.25 $\mu$ V) (Narrow) Mod : 1kHz Dev : $\pm$ 3.0kHz (Wide) Dev : $\pm$ 1.5kHz (Narrow)					

## Transmitter Section

Item	Condition	Measurement		Adjustment		Specifications/ Remarks
		Test equipment	Terminal	Parts	Method	
1. Frequency	1) CH : TX center 2) Transmit	Frequency counter	ANT	PC key	Adjust to center frequency	Within $\pm$ 100Hz
2. Maximum power limiting	1) CH : TX high 2) Transmit	Power meter		VR1	48W	$\pm$ 1W
3. High power	1) CH : TX low CH : TX low' CH : TX center CH : TX high' CH : TX high 2) Transmit			PC key	45W	$\pm$ 1.0W
4. Low power	1) CH : TX low CH : TX low' CH : TX center CH : TX high' CH : TX high 2) Transmit				25W	$\pm$ 1.0W

## ADJUSTMENT

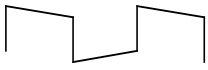
Item	Condition	Measurement		Adjustment		Specifications/ Remarks
		Test equipment	Terminal	Parts	Method	
5. DQT balance	1) CH : TX low (Wide) CH : TC center (Wide/Narrow) CH : TX high (Wide) 2) Transmit	Modulation analyzer or Linear detector (LPF : 3kHz) Oscilloscope	ANT	PC key	Adjust the waveform as below 	
6. MAX balance	1) CH : TX low (Wide) CH : TC center (Wide/Narrow) CH : TX high (Wide) 2) AG : 1kHz/50mV 3) Transmit	Modulation analyzer or Linear detector (LPF : 15kHz) Oscilloscope AG	ANT MIC		±4.0kHz (Wide) ±2.0kHz (Narrow) According to the large +, -	±50Hz
7. MIC sensitivity	1) CH : TX center (Wide/Narrow) 2) AG : 1kHz/5mV 3) Transmit	AF V.M			Check	±3kHz±0.2kHz (Wide) ±1.5kHz±0.1kHz (Narrow)
8. DQT deviation	1) CH : TX low (Wide) CH : TX center (Wide/Narrow) CH : TX high (Wide) 2) Transmit	Modulation analyzer or Linear detector (LPF : 3kHz) Oscilloscope			±0.75kHz (Wide) ±0.35kHz (Narrow)	±0.05kHz
9. QT deviation	1) CH : TX low (Wide) CH : TX center (Wide/Narrow) CH : TX high (Wide) 2) Transmit				±0.75kHz (Wide) ±0.35kHz (Narrow)	±0.05kHz
10. DTMF /MSK deviation	1) CH : TX center (Wide/Narrow) 2) Transmit				±3.0kHz (Wide) ±1.5kHz (Narrow)	±0.2kHz

**If normal power is not obtained, please follow the step below**

Open the shielding cover (upper), and screw 3 locations around ANT pin.

- Switch off the transceiver.  
Impedance of Final FET (Q504) and Drive FET (Q503) can be measured easily using DVM  $\Omega$  mode.  
Normal condition – Gate : 20k $\Omega$ ~50k $\Omega$ , Drain : 1M $\Omega$ ~2M $\Omega$   
The above impedance values are rough estimations.
- Switch on the transceiver. Check the voltage at R823 output point.  
The voltage is around 13.6V in receiving condition. The voltage will be 12.6V~ in transmitting condition.
- Remove R525.

- Connect 50 $\Omega$  load at the ANT location.  
Transmit and check current drain at High power mode.  
If the current drain is less than 1A, then Final FET is broken.  
If the current drain is less than 5.0A, short the Drive FET gate to ground, and check the current drain.  
If the current drain is not 0.1A less than the original value, then the Drive FET is broken.
- Check input power level at Drive FET gate location.  
Connect the wire to [RF] location.  
Transmit and check for power to be within the range of 0.7W~1W.  
If power found is less than 0.5W, check the circuit before the Drive FET.

## TERMINAL FUNCTION

### CN2

No.	Name	I/O	Function
1	SB	O	Battery voltage DC supply
2	NC	-	-
3	GND	O	Ground
4	NC	-	-
5	FNC1	I/O	Programable I/O (programmed by FPU)
6	FNC2	I/O	Programable I/O (programmed by FPU)
7	FNC3	I/O	Programable I/O (programmed by FPU)
8	FNC4	I/O	Programable I/O (programmed by FPU)
9	FNC5	I/O	Programable I/O (programmed by FPU)
10	FNC6	I/O	Programable I/O (programmed by FPU)
11	FNC7	I/O	Programable I/O (programmed by FPU)
12	FNC8	I/O	Programable I/O (programmed by FPU)

### ■ Function Port Assignment

KDS100, KGP-2A/2B		
	Name	I/O
FNC1	-	-
FNC2	-	-
FNC3	Data Channel	I
FNC4	PTT	I
FNC5	Carrier Operated Relay	O
FNC6	Audio Mute	I
FNC7	Mic Mute	I
FNC8	TX Relay	O
SmarTrunk II		
	Name	I/O
FNC1	TXD	O
FNC2	RXD	I
FNC3	Reset	O
FNC4	-	-
FNC5	-	-
FNC6	-	-
FNC7	-	-
FNC8	-	-
Scrambler		
	Name	I/O
FNC1	-	-
FNC2	-	-
FNC3	TX Relay	O
FNC4	Scrambler	O
FNC5	Scrambler Code1 (1)	O
FNC6	Scrambler Code2 (2)	O
FNC7	Scrambler Code3 (4)	O
FNC8	Scrambler Code4 (8)	O

Port Function is Low Active. (Exclude : Scrambler Code)

### CN3

No.	Name	I/O	Function
1	IGN	I	Ignition sens input
2	DATAI	I	External transmit signal input
3	DETO	O	FM detector output
4	TXAFI	I	TX audio input from scrambler board
5	TXAFO	O	TX audio output to scrambler board
6	EMGMIC	I	Emergency MIC input (1kHz/1.2mVrms)
7	RXAFO	O	RX audio output to scrambler board
8	ALTI	I	External alert tone signal input
9	RXAFI	I	RX audio input from scrambler board
10	5C	O	5V DC power supply (50mA MAX)
11	8C	O	8V DC power supply (50mA MAX)

### CN4

No.	Name	I/O	Function
1	GND	O	Ground
2	NC	-	-
3	NC	-	-
4	NC	-	-
5	FNC2	I/O	Programable I/O (programmed by FPU)
6	NC	-	-
7	NC	-	-
8	FNC3	I/O	Programable I/O (programmed by FPU)
9	FNC1	I/O	Programable I/O (programmed by FPU)
10	NC	-	-
11	5C	O	5V DC power supply (50mA MAX)
12	NC	-	-
13	DATAI	I	External transmit signal input
14	DETO2	O	FM detector output
15	ALTI	I	External alert tone signal input
16	NC	-	-
17	NC	-	-
18	NC	-	-
19	NC	-	-
20	GND	O	Ground

DISPLAY UNIT (X54-3430-20) Component side view (J72-0885-09)

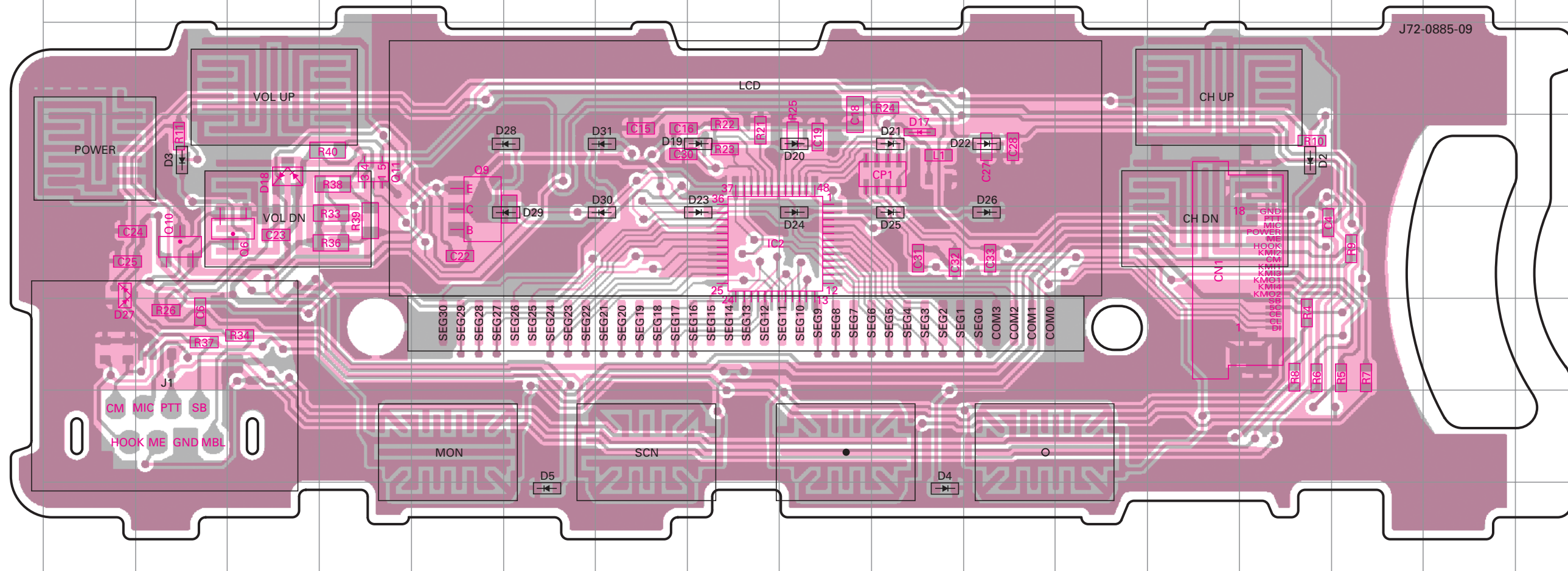

Ref. No.	Address	Ref. No.	Address
IC2	4H	D20	3I
Q6	4C	D21	3J
Q9	4E	D22	3K
Q10	4B	D23	4H
Q11	3D	D24	4L
D2	3N	D25	4J
D3	3B	D26	4K
D4	7J	D27	4A
D5	7F	D28	3F
D17	3J	D29	4F
D18	3C	D30	4G
D19	3H	D31	3G

DISPLAY UNIT (X54-3430-20) Foil side view (J72-0885-09)

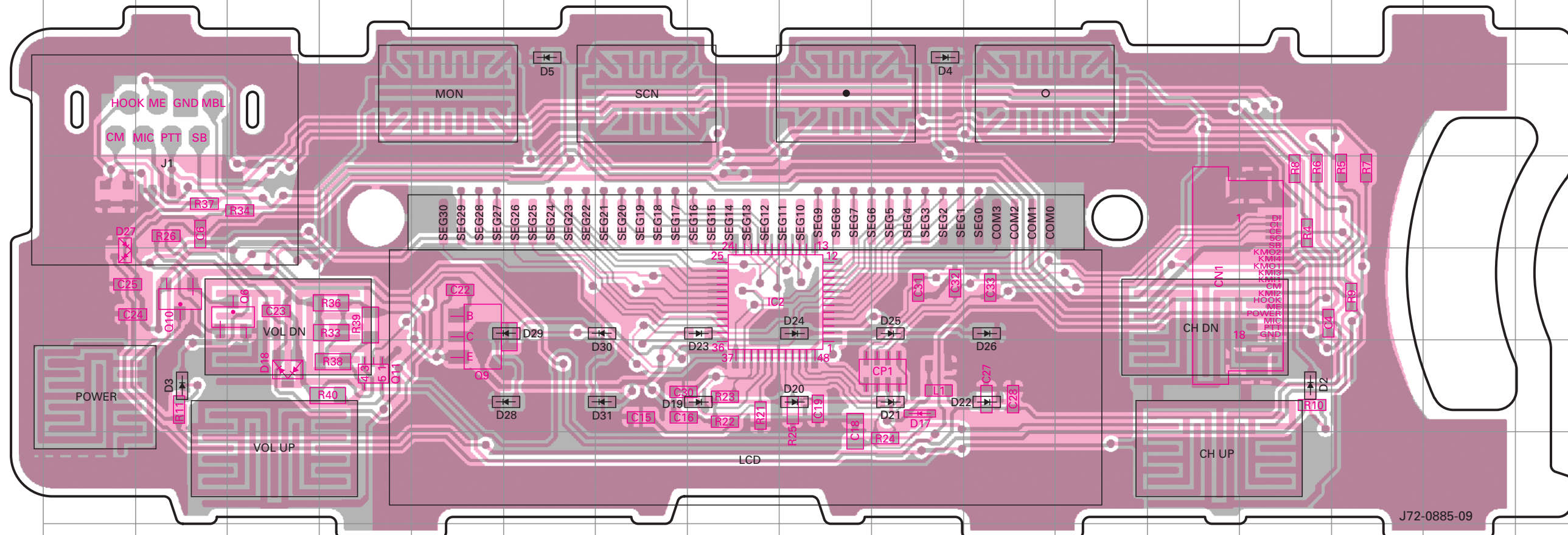

Ref. No.	Address	Ref. No.	Address
IC2	11H	D20	12I
Q6	11C	D21	12J
Q9	11E	D22	12K
Q10	11B	D23	11H
Q11	12D	D24	11I
D2	12N	D25	11J
D3	12B	D26	11K
D4	8J	D27	11A
D5	8F	D28	12F
D17	12J	D29	11F
D18	12C	D30	11G
D19	12H	D31	12G

Component side  
 Foil side



# TK-8100H PC BOARD

## TX-RX UNIT (X57-6710-XX) -21 : K -22 : K2 -23 : K3 Component side view (J72-0887-19)

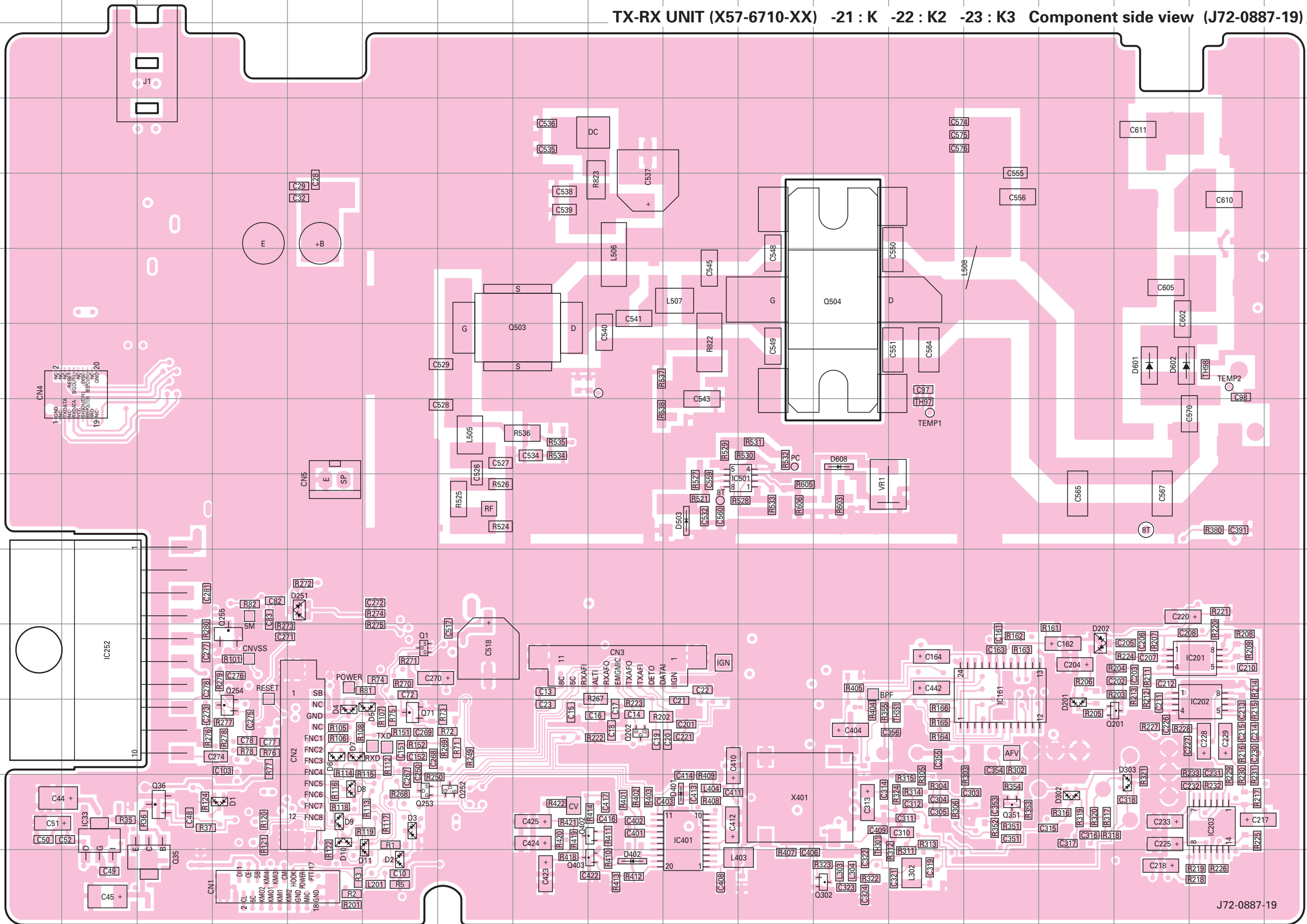

Ref. No.	Address
IC33	12B
IC161	10N
IC201	10Q
IC202	11Q
IC203	12Q
IC252	10B
IC401	12J
IC501	8K
Q1	10F
Q35	13C
Q36	12C
Q71	11F
Q201	11P
Q202	11I
Q252	12G
Q253	12F
Q254	11D
Q255	10D
Q302	13L
Q351	12N
Q402	12I
Q403	13I
Q503	6H
Q504	5L
D1	12D
D2	13F
D3	12F
D4	11E
D5	11F
D6	11E
D7	11E
D8	12E
D9	12E
D10	12E
D11	12F
D201	11O
D202	10O
D251	9E
D302	12O
D303	12P
D401	12J
D402	13I
D503	8J
D601	6P
D602	6P
D608	7L

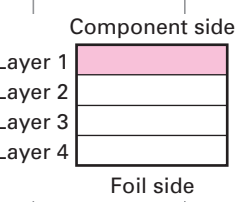

# PC BOARD TK-8100H

## TX-RX UNIT (X57-6710-XX) -21 : K -22 : K2 -23 : K3 Foil side view (J72-0887-19)

Ref. No.	Address
IC31	12R
IC32	13Q
IC34	13N
IC35	12M
IC66	11M
IC101	11O
IC251	12C
IC301	12G
Q31	5R
Q32	4R
Q33	12Q
Q34	12Q
Q61	4R
Q86	10O
Q87	10P
Q251	11C
Q301	13G
Q352	10H
Q353	10D
Q404	12J
Q405	11K
Q406	13L
Q407	11J
Q410	12K
Q411	11H
Q440	12J
Q500	10J
Q501	10K
Q502	9L
D31	3O
D32	5R
D61	4Q
D301	13H
D351	10E
D352	10D
D353	10C
D354	9D
D355	9C
D403	11L
D404	11L
D405	12L
D406	12L
D407	12L
D408	12J
D409	10H
D502	10L
D604	6B
D605	6B
D606	5C
D607	4C

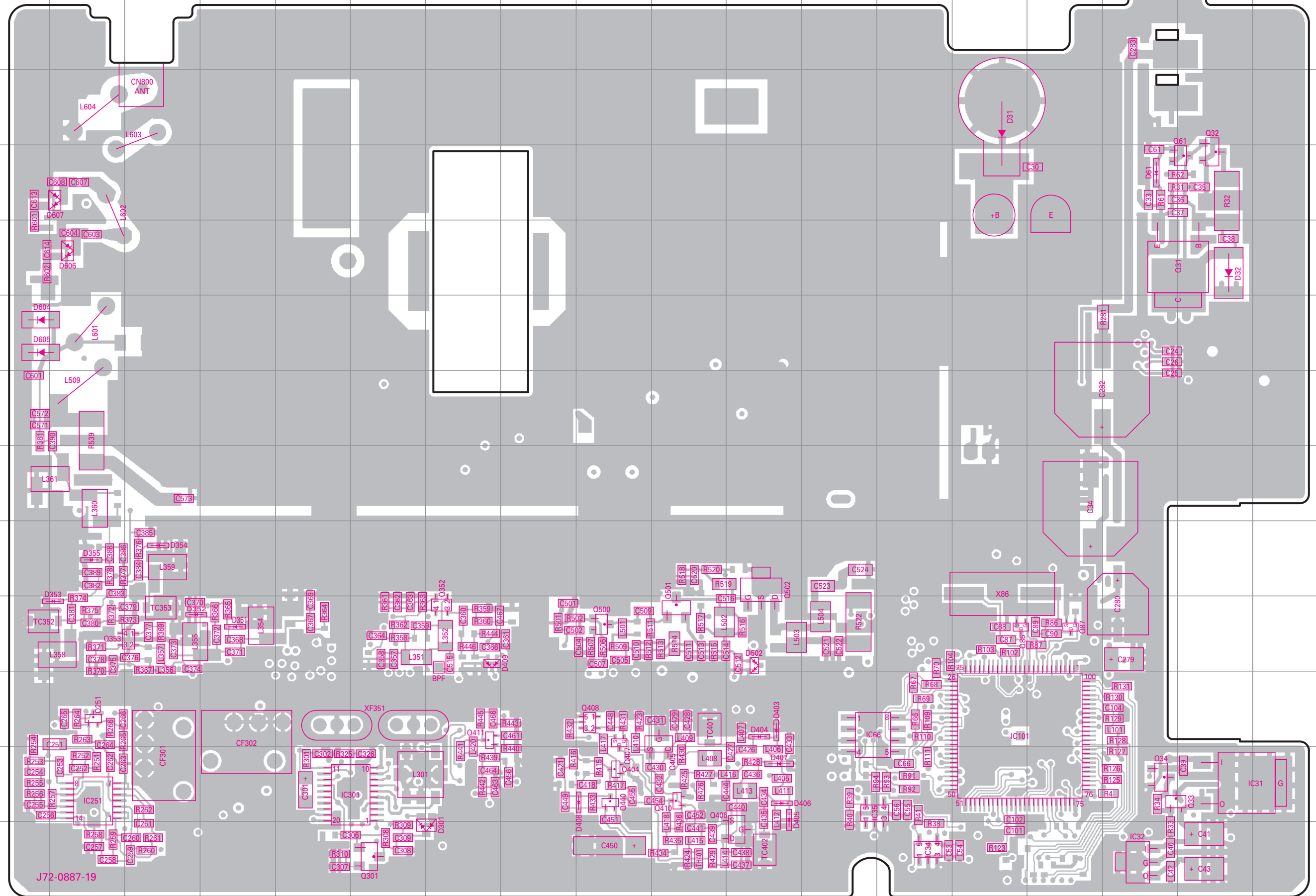

Component side

Layer 1
Layer 2
Layer 3
Layer 4

Foil side

J72-0887-19







Note : The components marked with a dot (•) are parts of layer 1.

# SCHEMATIC DIAGRAM TK-8100H

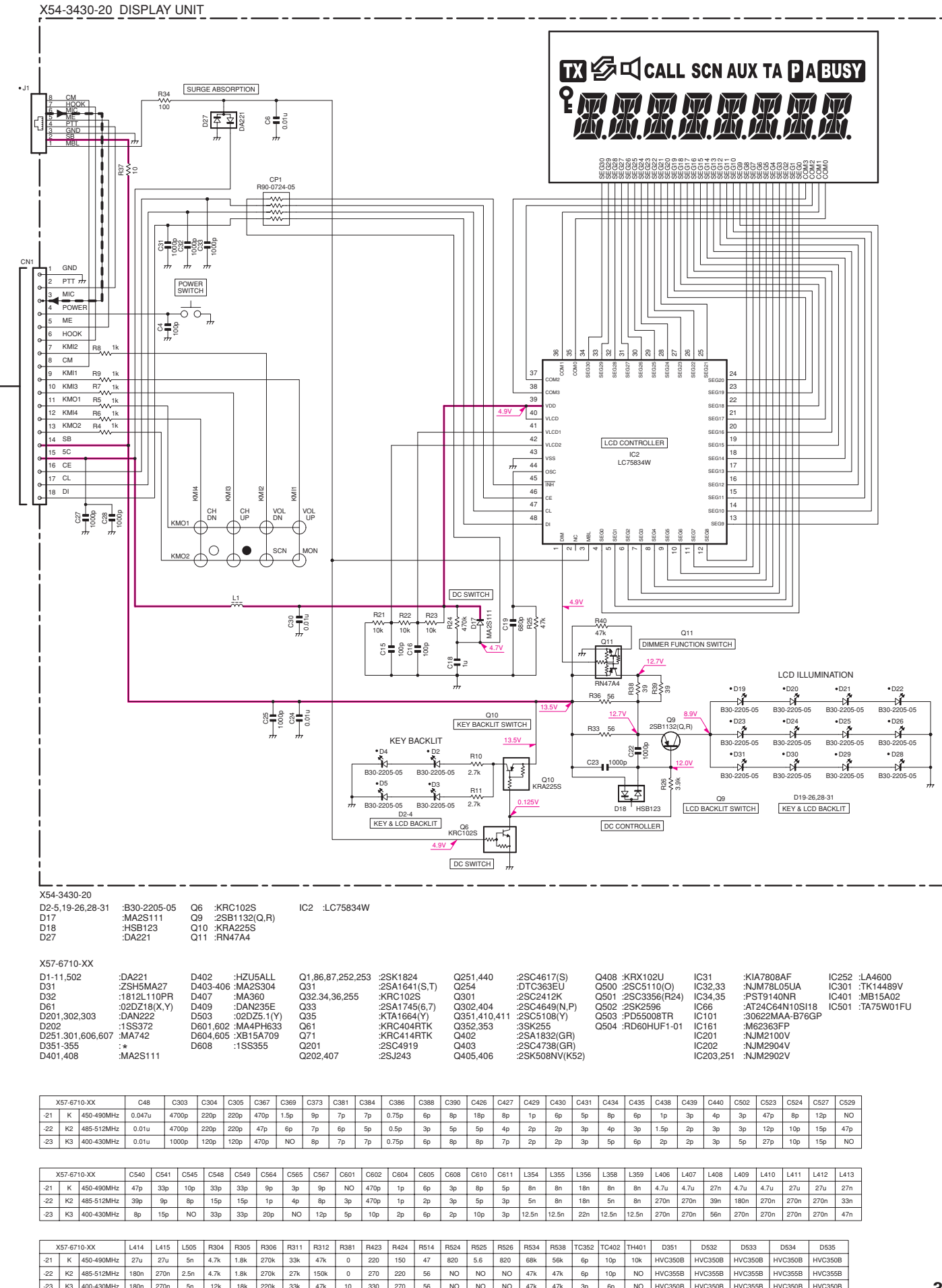
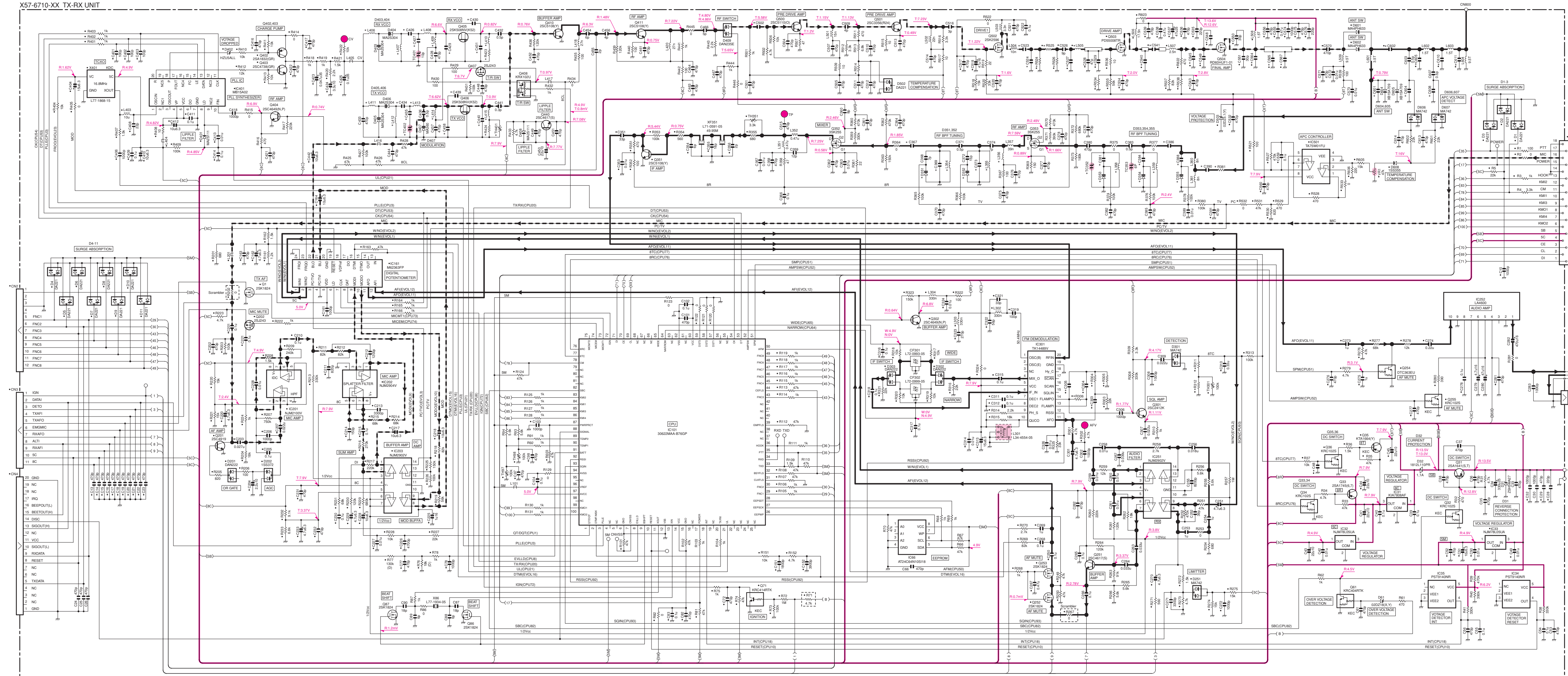

X57-6710-XX	D11-1.502	DA221	D402	H2USALL	O1.86.87.252.253	2SK1824	Q251.440	2SC4617(S)	Q408	KRX102U	IC31	40A7890AF	IC252	LA4600
	D031	ZS81MA27	D403	MA230A	Q31	2SA1641(S,T)	Q251.440	2SC4617(S)	Q501	2SC3356(R24)	IC32	40A7890AF	IC253	LA4600
	D32	1812L10PR	D407	MA360	Q32	34.36.255	Q301	2SC2412K	Q502	2SC3356(R24)	IC33	40A7890AF	IC254	LA4600
	D51	00D21(X,Y)	D409	DAN25E	Q33	2SA1746(S,T)	Q302.404	2SC4648(N,P)	Q503	2SC4648(N,P)	IC34	40A7890AF	IC255	LA4600
	D001.302.303	DAN222	D410	DAN22	Q38	3022(S,T)	Q303	2SC4648(N,P)	Q504	2SC4648(N,P)	IC35	40A7890AF	IC256	LA4600
	D202	1SS372	D601.602	MA4PH33	Q61		Q352.353	3SK255	Q505	2SC4648(N,P)	IC36	40A7890AF	IC257	LA4600
	D251.301.606.607	MA742	D604.605	XD15A709	Q71		Q352.353	3SK255	Q506	2SC4648(N,P)	IC37	40A7890AF	IC258	LA4600
	D351-355	MA2S11	D608	1SS355	Q201		Q403	2SC4738(GR)	Q507	2SC4738(GR)	IC38	40A7890AF	IC259	LA4600
	D401.408				Q202		Q405.406	2SK508(N,K52)	Q508	2SK508(N,K52)	IC39	40A7890AF	IC260	LA4600

X57-6710-XX	C48	C303	C304	C305	C367	C369	C373	C381	C384	C386	C388	C390	C426	C429	C430	C431	C434	C435	C438	C439	C440	C602	C623	C624	C627	C629
21	K	450-490MHZ	0.1uF	470p	220p	220p	47p	15p	5p	7p	7p	0.75p	6p	1p	1p	1p	1p	1p	1p	1p	1p	1p	1p	1p	1p	1p
22	K	485-512MHZ	0.01uF	470p	220p	220p	47p	15p	5p	7p	7p	0.75p	6p	1p	1p	1p	1p	1p	1p	1p	1p	1p	1p	1p	1p	1p
23	K	400-430MHZ	0.01uF	1000p	100p	100p	470p	NO	NO	NO	NO	NO	NO	NO	NO	NO	NO	NO	NO	NO	NO	NO	NO	NO	NO	

X57-6710-XX	L414	L415	L405	R304	R305	R306	R311	R312	R381	R423	R424	R434	R435	R436	R437	R438	R439	R440	R441	R442	R443	R444	R445	R446	R447	R448
21	K	450-490MHZ	27u	27u	5n	4.7k	1.8k	270k	33k	47k	0	200	150	47	800	5.6k	820	68k	50k	6p	10p	10k	HVC3508	HVC3508	HVC3508	HVC3508
22	K	485-512MHZ	180n	270n	2.5n	4.7k	1.8k	270k	27k	15k	0	270	220	56	NO	NO	NO	NO	NO	NO	NO	NO	NO	NO	NO	NO
23	K	400-430MHZ	180n	270n	5n	12k	18k	220k	33k	47k	0	300	270	56	NO	NO	NO	NO	NO	NO	NO	NO	NO	NO	NO	NO

# TK-8100H TK-8100H

## BLOCK DIAGRAM

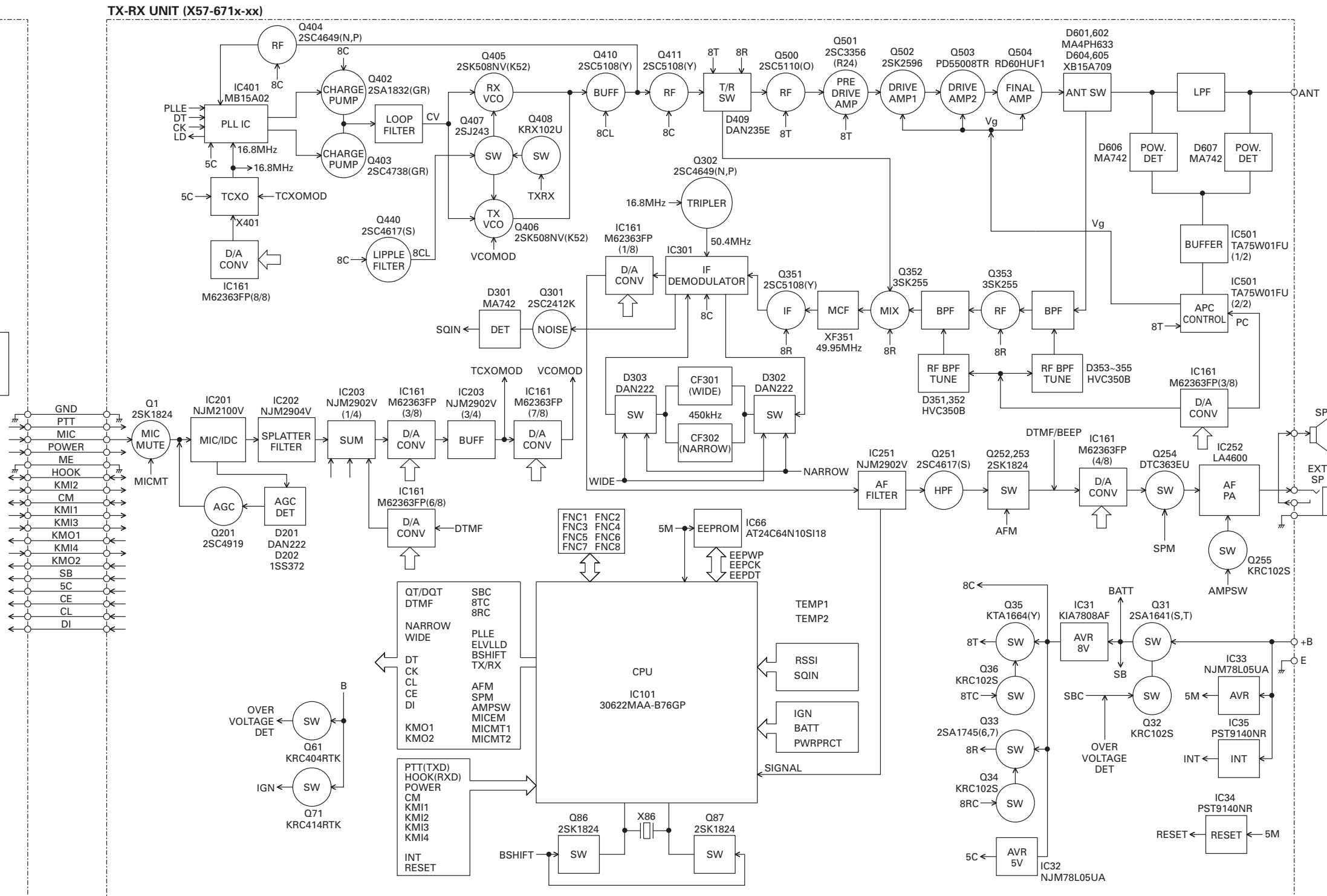
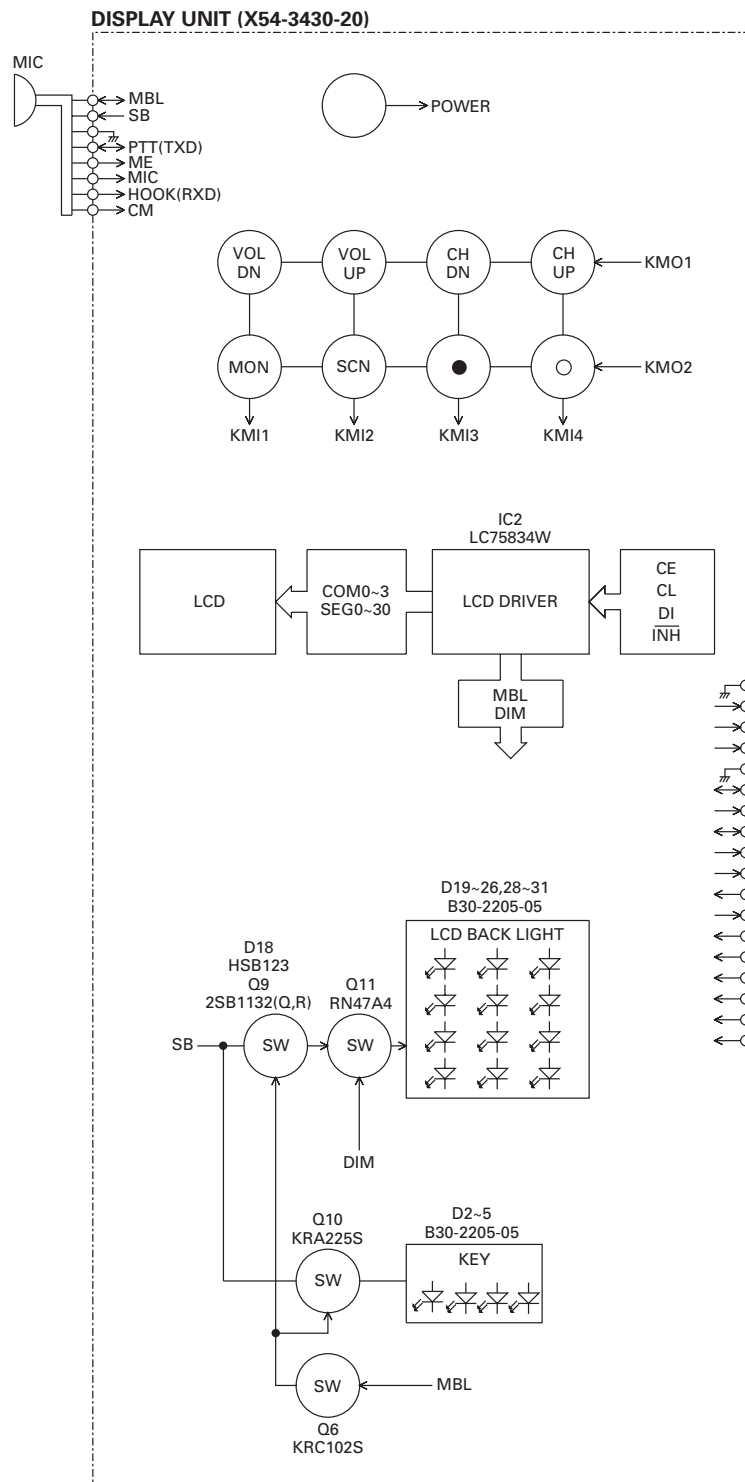

# TK-8100H TK-8100H

## LEVEL DIAGRAM

### Receiver Section

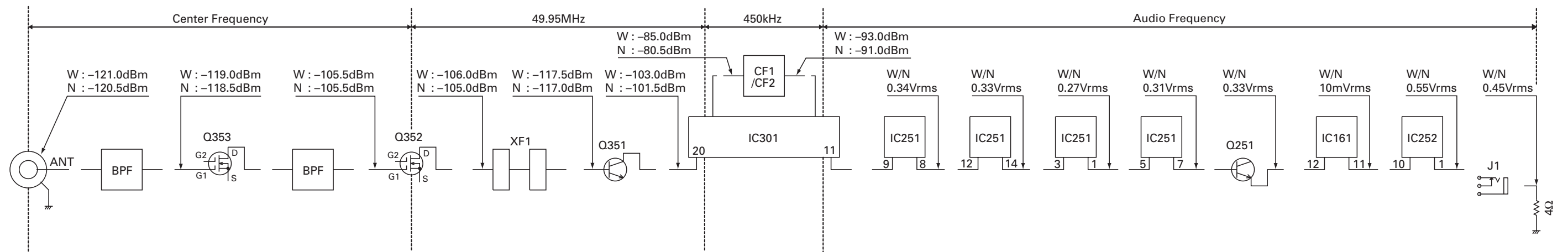

To make measurements in the RF section, connect the RF level meter.  
In the RF section, use a 0.01μF coupling capacitor.  
(The display shows the SSG input value required to obtain 12dB SINAD.)

To make measurements in the AF section, connect the AC level meter.  
(ANT input : -53dBm, 1kHz FM, 3kHz DEV (Wide)/1.5kHz DEV (Narrow))  
The AF output level is adjusted for a 0.45V/4Ω by the front panel AF VOL control.

### Transmitter Section

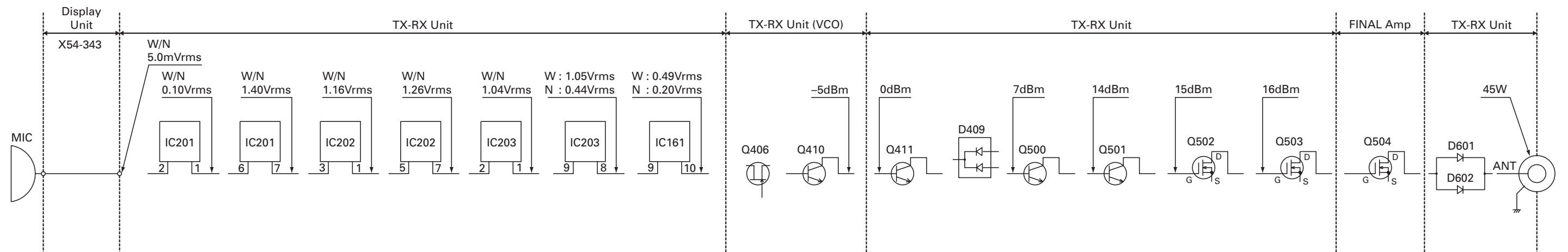

To make measurements in the AF section, connect the AC level meter.  
AG is set so that MIC input becomes 3kHz/1.5kHz (Wide/Narrow) DEV at 1kHz MOD.

To make measurements in the RF section, connect the RF Wattmeter (50Ω).

## SPECIFICATIONS

### GENERAL

Frequency Range .....	K : 450 to 490MHz	K2 : 485 to 512MHz	K3 : 400 to 430MHz
Channels / Groups .....	64CH / 8GRP		
Channel Spacing .....	Wide : 25kHz	Narrow : 12.5kHz	
PLL Channel Stepping .....	5.0, 6.25kHz		
Operating Voltage .....	13.6V DC $\pm$ 15%		
Current Drain .....	Less than 0.4A on standby		
	Less than 1.0A on receive		
	Less than 14.0A on transmit		
Operating Temperature Range .....	-30°C to +60°C		
Dimensions & Weight .....	6.30 (160) W x 1.70 (43) H x 5.40 (137) D inch (mm), 2.60 lbs (1.18kg)		
Channel Frequency Spread .....	K : 40MHz	K2 : 27MHz	K3 : 30MHz

### RECEIVER (Measurements made per EIA standard EIA/TIA-603)

Sensitivity (12dB SINAD) .....	Wide : 0.28 $\mu$ V	Narrow : 0.35 $\mu$ V
Selectivity .....	Wide : 75dB	Narrow : 65dB
Intermodulation .....	Wide : 70dB	Narrow : 60dB
Spurious Response .....	75dB	
Audio Power Output .....	4.0W	
Frequency Stability .....	$\pm$ 2.5ppm	

### TRANSMITTER (Measurements made per EIA standard EIA/TIA-603)

RF Power Output .....	High : 45W	Low : 25W
Spurious and Harmonics .....	70dB	
Modulation .....	Wide : 16K0F3E	Narrow : 11K0F3E
FM Noise .....	Wide : 45dB	Narrow : 40dB
Audio Distortion .....	Less than 3%	
Frequency Stability .....	$\pm$ 2.5ppm	



# TK-8100H

## **KENWOOD CORPORATION**

2967-3, Ishikawa-machi, Hachioji-shi, Tokyo 192-8525, Japan

### **KENWOOD U.S.A. CORPORATION**

P.O. BOX 22745, 2201 East Dominguez Street, Long Beach, CA 90801-5745, U.S.A.

### **KENWOOD ELECTRONICS CANADA INC.**

6070 Kestrel Road, Mississauga, Ontario, Canada L5T 1S8

### **KENWOOD ELECTRONICS DEUTSCHLAND GMBH**

Rembrücker Str. 15, 63150 Heusenstamm, Germany

### **KENWOOD ELECTRONICS BELGIUM N.V.**

Leuvensesteenweg 248 J, 1800 Vilvoorde, Belgium

### **KENWOOD ELECTRONICS FRANCE S.A.**

13, Boulevard Ney, 75018 Paris, France

### **KENWOOD ELECTRONICS U.K. LIMITED**

KENWOOD House, Dwight Road, Watford, Herts., WD18 9EB United Kingdom

### **KENWOOD ELECTRONICS EUROPE B.V.**

Amsterdamseseweg 37, 1422 AC Uithoorn, The Netherlands

### **KENWOOD ELECTRONICS ITALIA S.p.A.**

Via G. Sirtori, 7/9 20129 Milano, Italy

### **KENWOOD IBERICA S.A.**

Bolivia, 239-08020 Barcelona, Spain

### **KENWOOD ELECTRONICS AUSTRALIA PTY. LTD.**

(A.C.N. 001 499 074)

16 Giffnock Avenue, Centrecourt Estate, North Ryde, N.S.W. 2113 Australia

### **KENWOOD ELECTRONICS (HONG KONG) LTD.**

Unit 3712-3724, Level 37, Tower one Metroplaza, 223 Hing Fong Road, Kwai Fong, N.T., Hong Kong

### **KENWOOD ELECTRONICS TECHNOLOGIES(S) PTE LTD.**

Sales Marketing Division

1 Ang Mo Kio Street 63, Singapore 569110

